

COTTOD'ESTE  
Nuove Superfici

kerlite®  
GENERAL BOOK AND REFERENCES



**kerlite**<sup>®</sup>  
GENERAL **BOOK** AND **REFERENCES**

**COTTOD'ESTE** | LA  
Nuove Superfici | BELLEZZA  
IN  
CERAMICA

## OUR GROUP

# PANARIAGROUP THROUGHOUT TIME AND AROUND THE WORLD, CERAMIC EXCELLENCE

To excel in the world of high quality ceramics means knowing how to continuously create highly technological products and how to enhance them through the utmost attention to aesthetics and detail.

Panariagroup has always adhered to the highest standards of excellence, combining its history of skilful artisan craftsmanship with cutting edge technology.

This approach is intrinsically linked to a fundamental commitment to always act and operate responsibly.

With over 40 years of experience, Panariagroup is an international company with a strong Italian soul and an extensive sales network with 8 brands in over 130 countries all over the world.





Parco Verticale, Porta Nuova - Milano  
 Development and Property - COIMA, Interior Design - COIMA Image  
 Made with Panariagroup products

## KERLITE SLABS

BEAUTY IN CERAMICS	6
SUPERIOR QUALITY THIN CERAMIC SLABS	9
KERLITE INTENDES USES	12
GREEN MISSION	14
PROTECT ANTIBACTERIAL SURFACE	16

## SERIES

kerlite

thickness	3plus	5plus	6plus	page.
<b>MARBLE AND STONE</b>				<b>18</b>
BUXY	•			20
CLUNY (P)	•	•		24
ELEGANCE (P)		•		30
EXEDRA (P)		•		34
LIMESTONE (P)		•		40
LITHOS (P)			•	44
PIETRA D'ISEO (P)			•	50
VANITY (P)			•	54
<b>CONCRETE AND RESIN</b>				<b>66</b>
CEMENT PROJECT (P)		•		68
MATERICA (P)		•		78
OVER	•			84
<b>WOOD</b>				<b>90</b>
FOREST (P)		•		92
WOODLAND (P)			•	98
<b>OTHER SURFACES</b>				<b>106</b>
BLACK - WHITE (P)	•	•		108
METAL (P)		•		114
WONDERWALL (P)	•			118

## REFERENCES

127

### OUTDOOR

REARTH HEADQUARTER BUILDING	128
SIEMES HEADQUARTER	130
INTERNATIONAL BUSINESS CENTER	132
REALE GROUP HEADQUARTERS	134
FASTWEB HEADQUARTER	136
FLORENCE NEW OPERA HOUSE	138
PÉCS ZOO	142
HOTEL PANGEA & NYÍREGYHÁZA ZOO	144
RESIDENCE LIDO RICCIO	146
PRIVATE HOUSE	148

### INDOOR

CHONGQING WEST - RAILWAY STATION	150
SHANGHAI CAOHEJING HI-TECH PARK	154
UNIPOL TOWER	156
NEW HIGH-SPEED BOLOGNA CENTRAL STATION	158
NUMBER A1 VAR TUNNEL	160
PRIVATE HOUSE	162
PRIVATE HOUSE	164

### TECHNICAL BOOKLET

166

VENTILATED FACADE SYSTEM	167
KERLITE EASY	169
TECHNICAL CHARACTERISTICS	176
SIZES	184
CERTIFICATIONS	186



# BEAUTY IN CERAMICS



**THE NEW SURFACE  
FOR ARCHITECTURE**

Cotto d'Este has distinguished itself as one of the most prestigious names in the field of ceramics. Our creations recall beauty, quality and prestige and are the result of our passionate and continuous aesthetic research. Rather than a mission, searching for beauty is a vocation, an imperative that has allowed us to attain a high level of excellence, as attested by the confidence placed in our creations by architects and interior designers all over the world.

## SLABS PRESSED ON CONTINUOUS BELTS AND NOT TILES MADE WITH CONVENTIONAL DIES

Kerlite is ultrathin porcelain stoneware based on a new concept, where maximum versatility and ease-of-use are the strong points. Resistant and light, flat and flexible, simple to cut, drill and install, and easy to sanitise too. Developed to fulfil the aesthetic needs of architecture and contemporary design, Kerlite introduces the era of global tiling: not only floors and walls but also furniture and furnishings, doors, kitchens and work tops.

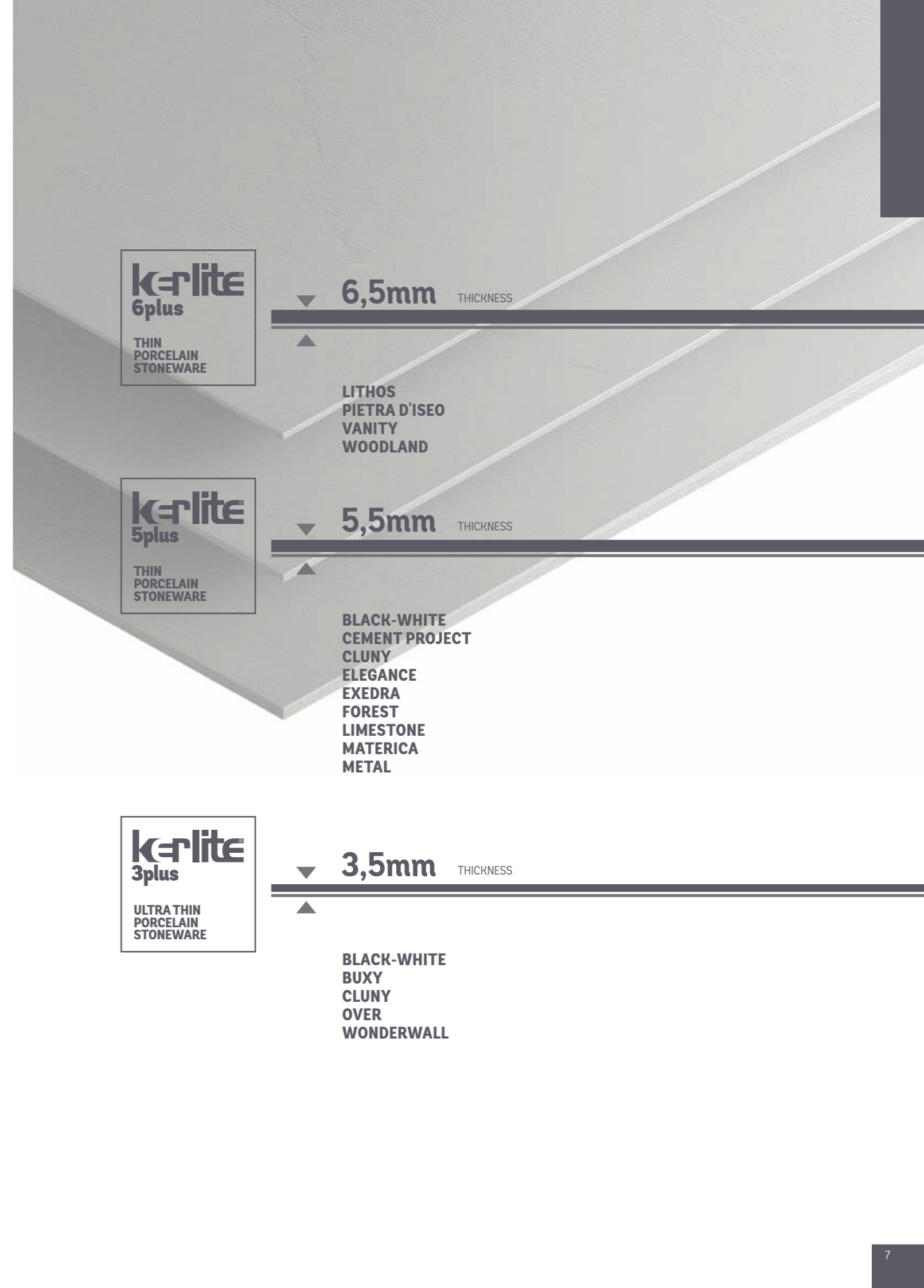

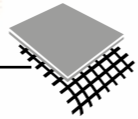

Reinforced with fibreglass on the rear side

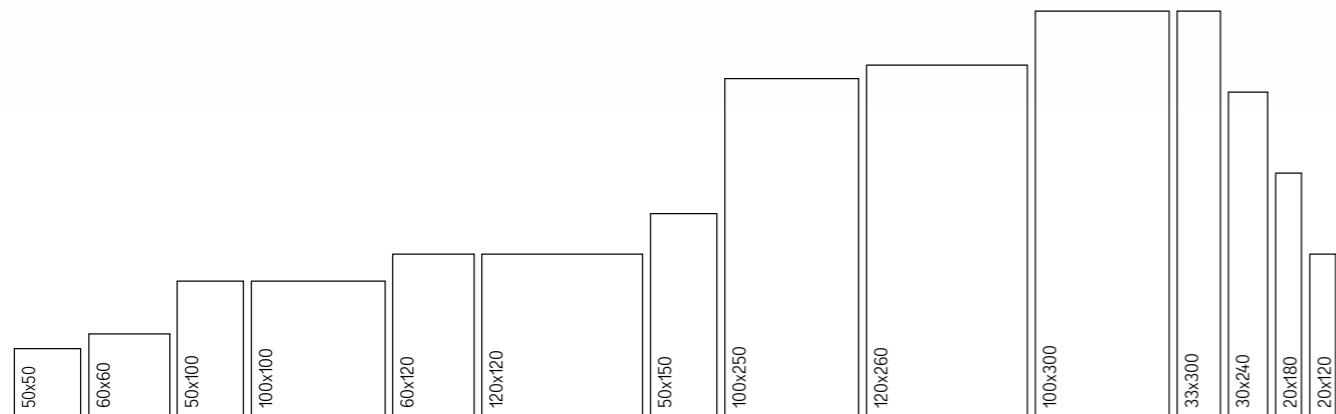

**Ideal for flooring and wall cladding** both for new buildings and for renovation, including projects with tiling laid on pre-existing floor:

**Kerlite 3plus**  
3,5mm

Ideal in residential and light commercial spaces.

**Kerlite 5plus**  
5,5mm

Ideal in residential and commercial spaces including those subjected to heavy traffic.

**Kerlite 6plus**  
6,5mm

**kerlite**<sup>®</sup>

# SUPERIOR QUALITY THIN CERAMIC SLABS

**Large-sized laminated porcelain stoneware reinforced with fibreglass:** a light, resistant and versatile product for new design perspectives in the world of architecture and housing.

**Highest standards in quality and performance**

Thanks to the use of the best raw materials

**Highly compact and elastic slabs**

Thanks to a unique pressing process

**Excellent aesthetic look of the products**

Thanks to exclusive surface processing technologies

**Extraordinary added resistance**

Thanks to the reinforcing fibreglass mesh

**Highly eco-friendly**

Less raw materials used, lower water and energy consumption and lower CO<sub>2</sub> emissions



METAL IRON | 5,5mm | 100x100cm / 39"x39"





**LARGE**  
A range of slabs with sizes up to 3 x 1 metres. The perfection of the slabs allows for installation with joints of only 1 mm.



**THIN AND LIGHT**  
Slabs of Kerlite are particularly thin and light.

**GUARANTEED FOR 20 YEARS**  
The beauty and extraordinary quality of our floors are values that resist time: resistance of surfaces to wear and frost is guaranteed for 20 years.



**ANTIMICROBIAL SURFACE**  
The technology used in PROTECT products, based on silver ions blocks the metabolism of bacteria, eliminating them and preventing their proliferation. Unlike other technologies, such as those based on the use of Titanium Dioxide, the protective shield is always active, day and night, with or without sunlight and it does not need UV rays for activation..

**FLAT AND RESISTANT**  
The innovative production process of Kerlite, which is pressed on a continuous belt, allows us to produce perfectly flat and compact slabs. Pressed at a force of 15,000 tons, Kerlite 5plus resists breaking loads of up to 1200 Newton.

**EASY TO CLEAN**  
Kerlite is non-absorbent, easy to clean and resists acid, stains and pollution.  
**EASY TO INSTALL**  
Thin and light, easy to cut and drill, processing time reduced by 40% with respect to traditional tile.

**ECO-FRIENDLY**  
An ecocompatible production process: minus 70% on consumption of raw materials and water and minus 50% on natural gas; Emissions of CO<sub>2</sub> that are 20 times lower with respect to the thresholds of Italian laws, as envisaged by the Kyoto Protocol.



# INTENDED USES



Installation must be performed in compliance with the standards published on the Kerlite Technical Manual.

	<b>FLOOR INSTALLATION</b> For new buildings and refurbishing with installation on existing floors.	<b>3plus</b>	<b>5plus</b>	<b>6plus</b>
<b>INTERIORS</b>	<b>Residential</b> (kitchens, bathrooms, living rooms, common apartment block areas and any other residential environment).	● except: WONDERWALL (Items decorated with cold digital technology)*	●	●
	<b>Light commercial</b> (offices, offices open to the general public, waiting rooms, shops, bathrooms, restaurant dining rooms, car showrooms, bars, cinemas, surgeries/clinics).	● except: OVER SOFT - WONDERWALL (Items decorated with cold digital technology)*	● except: GLOSSY (EXEDRA - ULTRAWHITE)	●
	<b>Heavy duty commercial</b> (public areas of shopping centres, hotel halls, canteens, fast food restaurants, clubs, hospitals) with the exception of areas subject to heavy loads (e.g. trolleys with hard wheels).		● except: SILK (EXEDRA - ELEGANCE) - GLOSSY (EXEDRA - ULTRAWHITE)	● except: VANITY
<b>EXTERIORS</b>	Upon condition that surfaces are sheltered (e.g. loggias, covered balconies, etc.) and made totally impervious. The use of sizes that are not larger than 100x100 cm is recommended.	● except: WONDERWALL (Items decorated with cold digital technology)*	●	● except: VANITY
<b>WALL INSTALLATION</b> For new buildings and refurbishing with installation on existing floors.				
<b>INTERIORS</b>	Any residential and commercial area where holes and/or cuts are not necessary.	●	●	●
	Any residential and commercial area where holes and/or cuts are necessary.	●	●	●
<b>EXTERIORS</b>	On concrete or plaster supports, where corner cuts and large sizes are necessary.	● except: WONDERWALL (Items decorated with cold digital technology)*	●	●
	<b>SPECIAL USES</b>			
<b>VENTILATED FACADES, THERMAL INSULATION CLADDING SYSTEMS, TILING FOR SWIMMING POOLS, FOR FURNITURE SURFACES.</b>	Depending on project specifications and in combination with the construction systems recommended by Cotto d'Este and approved by the Installation Supervisor.	● except: WONDERWALL (Items decorated with cold digital technology)*	●	●

## LEGEND

	Residential	Light commercial	Intensive commercial
<b>3Plus (3,5mm)</b>			
BLACK-WHITE	naturale	naturale	
BUXY	naturale	naturale	
CLUNY	naturale	naturale	
OVER	naturale/soft	naturale	
WONDERWALL	matrix	matrix	
<b>5Plus (5,5mm)</b>			
BLACK-WHITE	glossy/silk	glossy/silk	
CEMENT PROJECT	cem/work	cem/work	cem/work
CLUNY	layé	layé	layé
ELEGANCE	silk	silk	
EXEDRA	silk/glossy	silk/glossy	
FOREST	naturale	naturale	naturale
LIMESTONE	natural	natural	natural
MATERICA	naturale	naturale	naturale
METAL	naturale	naturale	naturale
<b>6Plus (6,5mm)</b>			
LITHOS	naturale/soft	naturale/soft	naturale
PIETRA D'ISEO	naturale	naturale	naturale
VANITY	glossy/touch	glossy/touch	
WOODLAND	wild/soft	wild/soft	wild/soft

**Residential:** Kitchens, bathrooms, living rooms and other residential environments

**Light commercial:** Offices, offices open to the general public, waiting rooms, shops, public bathrooms, common apartment block areas, restaurant dining rooms, car showrooms, bars, cinemas, surgeries/clinics, hotel rooms and bathrooms. In areas subjected to forced traffic, it is not advisable to use products with the GLOSSY/TOUCH finishes.

**Intensive commercial:** Common areas of shopping centres, hotel foyers, canteens, fast food restaurants, dance clubs, hospitals, schools, museums, places of worship, airports, stations.

## NOTE

The GLOSSY/TOUCH finishes are recommended, as well as for wall cladding, also for flooring in residential or light commercial areas that are not subjected to heavy traffic, where anti-slip characteristics are not required. The occasional presence of small inconsistencies or little spots on the surface is to be considered a characteristic of the material and of its unique production process. If the product is laid in direct contact with external environments, it is recommended to use protective solutions to reduce the formation of scratches. In areas that are subjected to heavy concentrated loads it is not recommended to use low thickness products.



# green mission

## OUR COMMITMENT TOWARDS ECOCOMPATIBLE PRODUCTION

### FOR A PLANET THAT LIVES

Cotto d'Este has a green heart. Along with our passion for beauty, we cultivate an inborn sensitivity for the environment. Our company has made excellence its mission. We know that this implies concern for the environment and for protection of our planet. Our commitment is effective and binding and is the result of practical choices. Our target is a highly ecocompatible production process that is recognised at an international level by the most preminent environmental certification bodies. How do the beauty and quality of our products gain added value? They are the result of respect for our planet. A planet that lives.



The continuous search for excellence has led Cotto d'Este to invest in the latest technology. Amongst the many advantages, the latter has permitted us to reduce emission of gas into the atmosphere to the minimum levels possible: at least ten times lower than the strict thresholds of Italian laws. Emission levels also fulfil the requirements of the Kyoto Protocol for reduction of GHG.



By means of extremely modern plant, Cotto d'Este can convey the heat produced during the tile firing stage to the equipment used for preparing mixtures. By doing so, the consumption of natural gas is reduced by at least 25%.



All discarded green material - i.e. green material that does not fulfil our high standards of quality - is recycled. Since this material is not fired, it can be fed back into the initial stages of the production process hence reducing the amount of raw materials needed. Fired rejects that cannot be fed back into the production cycle, since they would adversely affect the characteristics of the mixture, are recycled externally. In other words, they are used for the production of bricks or road substrates thus reducing the natural materials generally used for these purposes.



The tile production process calls for a significant amount of water. To save such an important resource, Cotto d'Este recycles all the water employed during the production cycle. This reduces the consumption of water by 60%. Furthermore, the water used during the production process is in no manner disposed of in the environment.



All materials used for packing our products (cardboard boxes, plastic, wooden pallets, etc.) can be recycled. As a further environmental guarantee for the forests of countries importing our products, all our pallets are made without bark (in accordance to the IPPC / FAO ISPM 15 standard).



Apart from keeping a constant control on the work environment, Cotto d'Este invests in training courses for staff concerning the environmental and safety aspects of the production activities. We promote the reduction of noise levels both inside and outside our factories, as established by the laws in force.



To continuously improve its policy, Cotto d'Este periodically checks its entire environmental protection package by means of Environmental Audits performed by independent certifying bodies and by qualified in-house personnel.

### OUR ENVIRONMENTAL CERTIFICATIONS

UNI EN ISO 14001:2015



SISTEMA DI GESTIONE AMBIENTALE CERTIFICATO

ISO 14001



Stabilimento di FIORANO (MO)

EMAS



LEED

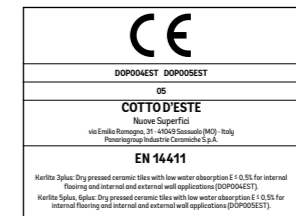

CE



EDP



GREENGUARD GOLD

All environmental certificates, declarations of conformity and environmental declarations can be found on the Cotto d'Este web site.

## TO LIVE HEALTHY, SAFE AND SECURE

The exclusive Panariagroup technology for antimicrobial floor and wall coverings with the highest performance



### POWERFUL ACTION

eliminates microbes and prevents their reproduction



### CONTINUOUS PROTECTION

always active, 24 hours a day, with and without sunlight



### ETERNAL EFFECTIVENESS

thanks to the technology permanently integrated into the product



### GUARANTEED QUALITY

by the partnership with  
**MICROBAN**

[protect.panariagroup.it](http://protect.panariagroup.it)

# P R ( ) T E C T

## WHY PROTECT® IS BETTER:

### • MORE HYGIENIC AND EASIER CLEANING

The level of cleanliness of the product can be visibly improved with PROTECT® antimicrobial technology, and while not a substitute for normal cleaning, it allows complete and easier cleaning, rendering it less expensive and allowing you to reach a better level of protection between cleaning operations.

### • IT ALSO ELIMINATES SUBSTANCES WHICH ARE NOT VISIBLE

Bacteria are invisible, but that doesn't mean they are not there! Thanks to PROTECT® antimicrobial technology the growth of bacteria is significantly limited on floor and wall tiles, kitchen countertops, etc.

### • LESS BACTERIA, LESS ODOURS

The presence of bacteria can cause odours, just think of the exercise equipment found in gyms. Reducing bacteria reduces the odours.

## ANTIMICROBIAL EVERYWHERE

The continuous antimicrobial action of the PROTECT® line prevents the formation of biofilms, colonies of bacteria that form a slimy coating on surfaces, which are difficult to clean and can compromise the tile itself by fading colours or adding resistant and smelly mildew. PROTECT® technology is especially effective with bacteria such as Escherichia coli, Klebsiella pneumoniae and Staphylococcus aureus, very frequent in any environment.

### PROTECT® ANTIMICROBIAL SURFACES ARE RECOMMENDED FOR DOMESTIC ENVIRONMENTS BUT ALSO:



#### Restaurants, canteens, countertops for kitchens

Greater hygiene in environments where the presence of food is essential.



#### Healthcare environments, medical clinics

A weakened and sensitive immune system requires the utmost care in these environments.



#### Gyms, health clubs, spas

Antimicrobial surfaces in sports and wellness centres are a guarantee of extreme care for clients.



#### Airports, shopping centres, schools

Centres with large numbers of people require strict controls to prevent bacteria growth

### EVERY PRODUCT CAN BE PROTECT®.

The antimicrobial technology can be integrated into all types of products, formats, surfaces, finishes including products created 'on demand'. Also, unlike other technologies, it does not whiten the surface in which it is incorporated.





## THE TWO SOULS OF ARCHITECTURE

If rock is the bone structure of the world, stone and marble are the two souls of human architecture. As inspiration for its creations, Cotto d'Este has selected the most beautiful stone and marble in the world: elegant and modern marble, with soft and delicate tones, veined or marbled surfaces, with a silky sheen; modern and minimalist stone, with a particularly striking depth-effect due to the inclusion of accurately selected and refined minerals in the body. Marble and stone presented as Kerlite ultrathin porcelain stoneware, made more precious still by the passion for beauty that distinguishes Cotto d'Este. A wide range of finishes and surfaces that combine beauty with practicality and easy cleaning, in accordance to the tradition of the best Italian ceramics.



# BUXY

NATURAL SPIRIT



FINISHING

**RECTIFIED**

THICKNESS



SIZES

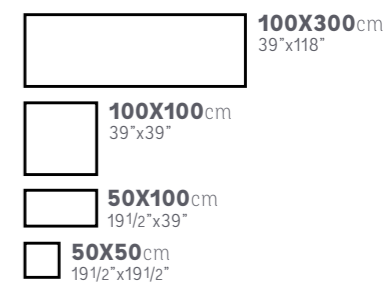

PERLE | 3.5 mm | 100x100 cm / 39"x39"

SLIP RESISTANCE



R10

DESHADING



V2

DEEP ABRASION RESISTANCE



175 mm<sup>3</sup>  
Average Value

TREAD MARK VISIBILITY



A Caramel, Perle, Noisette, Cendre  
B Corail Blanc, Amande

CLEANING EASINESS



1

COTTO D'ESTE GUARANTEE



20 YEARS  
RESIDENTIAL AND PUBLIC





CARAMEL | 3.5mm | 100x100cm / 39"x39"



Wall: NOISETTE | 3.5mm | 100x300cm / 39"x118"



CENDRE | 3.5mm | 100x300cm / 39"x118"





# CLUNY

ESPRIT NATUREL



ARGEROT



CHAMPAGNE



BOURGOGNE

FINISHING

**RECTIFIED**

THICKNESS

SURFACE

SIZES

**kerlite** 5plus  **Layé**

**100X300cm**  
39"x118"  
only argerot,  
champagne

**100X100cm**  
39"x39"  
only argerot,  
champagne

**kerlite** 3plus  **Naturele (P)**

**100X300cm**  
39"x118"

**100X100cm**  
39"x39"

BOURGOGNE NATURALE |  3,5mm | 100x300cm / 39"x118"

SLIP RESISTANCE

DESHADING

DEEP ABRASION RESISTANCE

TREAD MARK VISIBILITY

CLEANING EASINESS

ANTIMICROBIAL SURFACE

COTTO D'ESTE GUARANTEE

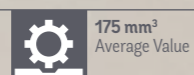

**PROTECT**  
ANTIMICROBIAL - 3PLUS







Cluny is available in two surfaces: NATURALE (3plus) opaque and structured,  
LAYE' (5plus) carved with deep scratch-like etching.







CHAMPAGNE LAYE' RETT. | ± 5,5mm | 100x300cm / 39"x118"



CLUNY





# ELEGANCE

SUPERIOR CLASS



VIA CONDOTTI



VIA MONTENAPOLEONE



VIA FARINI



VIA TORNABUONI

FINISHING

**RECTIFIED**

THICKNESS

**kerlite**  
5plus



SURFACE

**Silk**

SIZES



**100X300**cm  
39"x118"



**100X100**cm  
39"x39"

VIA TORNABUONI | ➔ 5,5 mm | 100x300cm / 39"x118"

DESHADING

DEEP ABRASION RESISTANCE

TREAD MARK VISIBILITY

CLEANING EASINESS

ANTIMICROBIAL SURFACE

COTTO D'ESTE GUARANTEE



V2



**175 mm<sup>3</sup>**  
Average Value



A Via Tornabuoni, Via Farini  
B Via Condotti, Via Montenapoleone



1 Via Tornabuoni, Via Farini  
2 Via Condotti, Via Montenapoleone

**PROTECT**  
ANTIMICROBIAL



**10 YEARS**  
RESIDENTIAL AND PUBLIC



VIA TORNABUONI | ➤ 5,5mm | 100x100cm / 39"x39"



VIA FARINI | ➤ 5,5mm | 100x300cm / 39"x118"

VIA MONTENAPOLEONE | ➤ 5,5mm | 100x300cm / 39"x118"







CALACATTA GLOSSY RETT. | ± 5,5 mm | 100x300 cm / 39"x118"

# EXEDRA

LUXURY STONE



ONYX EXTRA

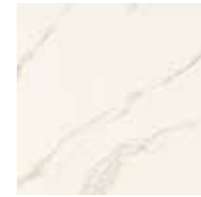

CALACATTA

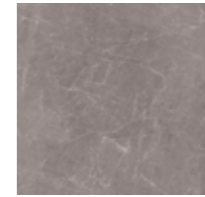

RAIN GREY

FINISHING

**RECTIFIED**

THICKNESS

SURFACE

SIZES

**kerlite**  
5plus



**Silk  
Glossy**

**100X300cm**  
39"x118"

**100X250cm**  
39"x98"

**100X100cm**  
39"x39"

**50X100cm**  
19 1/2"x39"

DESHADING

DEEP ABRASION RESISTANCE

TREAD MARK VISIBILITY

CLEANING EASINESS

ANTIMICROBIAL SURFACE

COTTO D'ESTE GUARANTEE

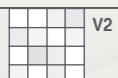

**PROTECT**  
ANTIMICROBIAL



**10 YEARS**  
RESIDENTIAL Glossy - Silk  
PUBLIC Silk











# LIMESTONE

STONE SURFACE

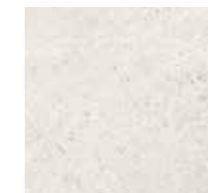

CLAY



AMBER



OYSTER



SLATE

FINISHING

**RECTIFIED**

THICKNESS

SURFACE

SIZES

**kerlite**  
5plus

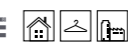

**Natural**

**100X300cm**  
39"x118"

**100X250cm**  
39"x98"

**100X100cm**  
39"x39"

**50X100cm**  
19 1/2"x39"

Floor: SLATE NATURAL | 5,5mm | 100x300cm / 39"x118" - Wall: CLAY NATURAL | 5,5mm | 100x300cm / 39"x118"

SLIP RESISTANCE

DESHADING

DEEP ABRASION RESISTANCE

TREAD MARK VISIBILITY

CLEANING EASINESS

ANTIMICROBIAL SURFACE

COTTO D'ESTE GUARANTEE



R10



V2



175 mm<sup>3</sup>  
Average Value



B



2

**PR( )TECT**  
ANTIMICROBIAL



**20 YEARS**  
RESIDENTIAL AND PUBLIC





MARBLE AND STONE

SLATE NATURAL | 5,5mm | 100x300cm / 39"x118"



CLAY NATURAL | 5,5mm | 100x300cm / 39"x118"

## LIMESTONE





Floor: **STONE SOFT** | 6.5mm | 120x120cm / 48"x48" - Wall: **CARBON NATURALE** | 6.5mm | 120x260cm / 48"x102"  
 Furniture: **CARBON NATURALE** | 6.5mm | 120x260cm / 48"x102" - Backsplash: **CARBON NATURALE** | 6.5mm | 120x260cm / 48"x102"

# LITHOS

THE NEW STONE



FINISHING

**RECTIFIED**

THICKNESS

SURFACE

SIZES

**kerlite**  
6plus



**Naturale**

**Soft**

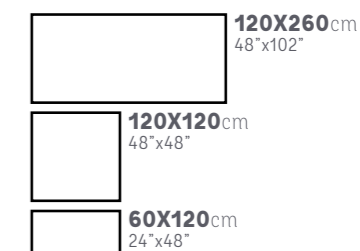

SLIP RESISTANCE

DESHADING

DEEP ABRASION RESISTANCE

TREAD MARK VISIBILITY

CLEANING EASINESS

ANTIMICROBIAL SURFACE

COTTO D'ESTE GUARANTEE



**R10**  
Naturale



**V2**



**175 mm<sup>3</sup>**  
Average Value



**A** Naturale (Desert, Carbon)  
**B** Naturale (Moon, Stone)



**2**

**PROTECT**  
ANTIMICROBIAL



**20 YEARS**  
RESIDENTIAL AND PUBLIC







MOON SOFT | 6,5mm | 120x120cm / 48"x48"

LITHOS





# PIETRA D'ISEO

DECORATIVE STONE



CEPPO





FINISHING

**RECTIFIED**

THICKNESS



SIZES

-  **120X260**cm  
48"x102"
-  **120X120**cm  
48"x48"
-  **60X120**cm  
24"x48"
-  **60X60**cm  
24"x24"

CEPPO | 6.5mm | 120x120cm / 48"x48"

SLIP RESISTANCE



DESHADING

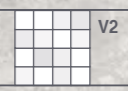

DEEP ABRASION RESISTANCE



TREAD MARK VISIBILITY



CLEANING EASINESS



ANTIMICROBIAL SURFACE



COTTO D'ESTE GUARANTEE











Floor: BIANCO LUCE GLOSSY | 6,5mm | 120x120cm / 48"x48" - Wall: BIANCO STATUARIO GLOSSY | 6,5mm | 120x260cm / 48"x102"

# VANITY

LUXURY MARBLE

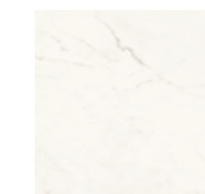

**BIANCO LUCE**



**BIANCO STATUARIO**



**DARK BROWN**



**MACCHIAVECCHIA**



**ONICE ROYAL**

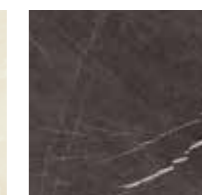

**PIETRA GREY**

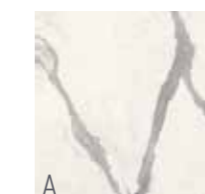

A

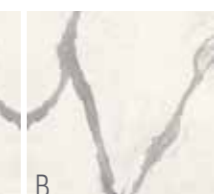

B

**BIANCO STATUARIO BOOKMATCH (A+B)**



A



B

**MACCHIAVECCHIA BOOKMATCH (A+B)**

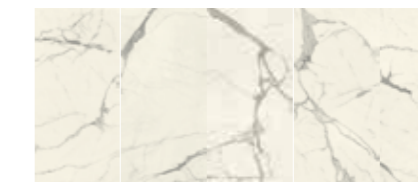

**BIANCO STATUARIO CHAIN (A+B+C+D+E)**



**MACCHIAVECCHIA CHAIN (A+B+C+D+E)**

FINISHING

**RECTIFIED**

THICKNESS

**kerlite 6plus**



SURFACE

**Glossy Touch**

SIZES

**120X260cm**  
48"x102"  
bookmatch A+B  
chain A+B+C+D+E

**120X120cm**  
48"x48"

**60X120cm**  
24"x48"

DESHADING

DEEP ABRASION RESISTANCE

TREAD MARK VISIBILITY

CLEANING EASINESS

ANTIMICROBIAL SURFACE

COTTO D'ESTE GUARANTEE

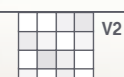

**PROTECT**  
ANTIMICROBIAL



















VANITY









## METROPOLITAN SURFACES

Designed for metropolitan environments, the Over and Materica series turn essentiality into a style, in line with the trends of contemporary minimalism. Surfaces inspired by hand-smoothed plaster and large polished concrete surfaces to create clear-cut and rigorous spaces that maintain a truly personal touch. Apparently monochrome, at a closer glance Materica reveals a subtle light-and-shade effect, which is a result of the waves recapturing the texture of hand-smoothed surfaces.





Floor: COLOR-40 CEM | 5.5 mm | 100x100 cm 39"x39"  
 Wall: COLOR-40 CEM | 5.5 mm | 100x100 cm 39"x39" - COLOR-00 CEM | 5.5 mm | 100x300 cm 39"x118"

# CEMENT PROJECT

URBAN SPACE



COLOR-10 WORK



COLOR-20 WORK



COLOR-30 WORK



COLOR-00 CEM



COLOR-10 CEM



COLOR-20 CEM



COLOR-30 CEM



COLOR-40 CEM

FINISHING

RECTIFIED

THICKNESS

SURFACE

SIZES

**Work**

**100X300cm**  
39"x118"

**50X150cm**  
19 1/2"x59"

**Cem**

**100X300cm**  
39"x118"

**100X100cm**  
39"x39"

SLIP RESISTANCE

DESHADING

DEEP ABRASION RESISTANCE

TREAD MARK VISIBILITY

CLEANING EASINESS

ANTIMICROBIAL SURFACE

COTTO D'ESTE GUARANTEE



R10 WORK  
R9 CEM



V2



175 mm<sup>3</sup>  
Average Value



A CEM Color 10, 20, 30, 40  
B WORK Color 00



1 CEM Color 10, 20, 30, 40  
2 WORK Color 00

**PROTECT**  
ANTIMICROBIAL



20 YEARS  
RESIDENTIAL AND PUBLIC



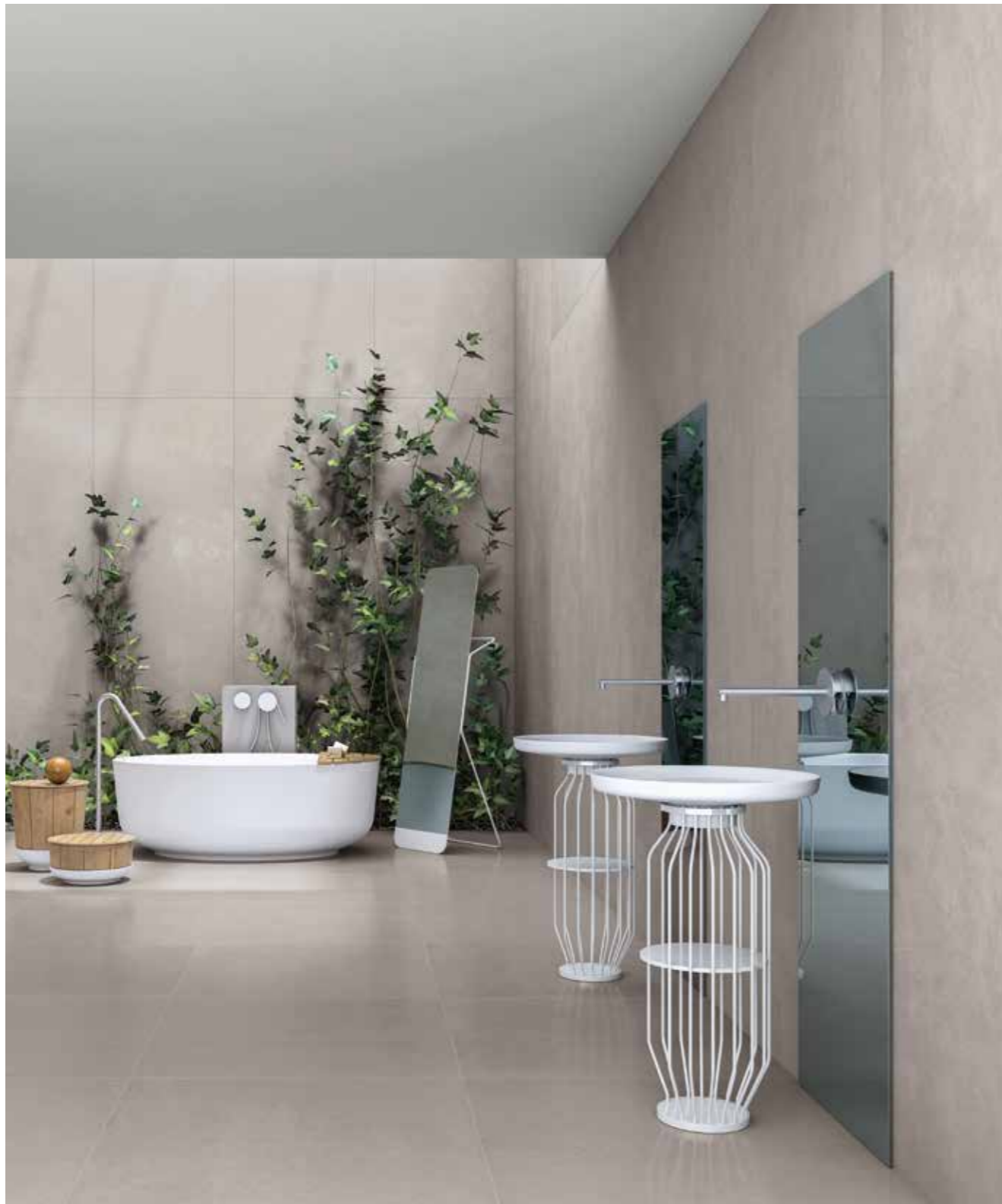

Wall: COLOR-20 CEM | 5,5 mm | 100x300 cm 39"x118"



Floor: COLOR-20 CEM | 5,5 mm | 100x300 cm 39"x118"  
Wall: COLOR-20 CEM | 5,5 mm | 100x300 cm 39"x118" - Ceiling: COLOR-20 WORK | 5,5 mm | 50x150 cm 13<sup>3</sup>/<sub>8</sub>"x59"

















TORTORA RETT. | ± 5,5 mm | 100x300 cm / 39"x118"

# MATERICA

NATURAL COLORS



FINISHING

**RECTIFIED**

THICKNESS

SIZES

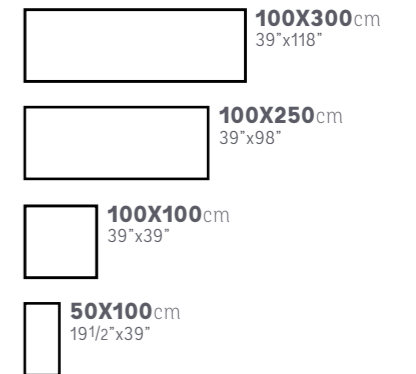

SLIP RESISTANCE

DESHADING

DEEP ABRASION RESISTANCE

TREAD MARK VISIBILITY

CLEANING EASINESS

ANTIMICROBIAL SURFACE

COTTO D'ESTE GUARANTEE



R9



V1



175 mm<sup>3</sup>  
Average Value



B Ardesia  
C Tortora, Bianco, Avorio



2

**PROTECT**  
ANTIMICROBIAL



20 YEARS  
RESIDENTIAL AND PUBLIC













Floor and wall: OFFICE NATURALE |  $\pm$  3,5mm | 100x100cm / 39"x39" - Table: ROAD NATURALE |  $\pm$  3,5mm | 100x300cm / 39"x118"

# OVER

THE URBAN SKIN



FINISHING  
**RECTIFIED**

THICKNESS	SURFACE	SIZES
	<b>Naturale</b>	<b>100X300cm</b> 39"x118"
		<b>100X100cm</b> 39"x39"
		<b>50X100cm</b> 19 1/2"x39"
		<b>50X50cm</b> 19 1/2"x19 1/2"
	<b>Soft</b>	<b>100X300cm</b> 39"x118"
		<b>100X100cm</b> 39"x39"

- SLIP RESISTANCE
- DESHADING
- DEEP ABRASION RESISTANCE
- TREAD MARK VISIBILITY
- CLEANING EASINESS
- COTTO D'ESTE GUARANTEE

R9 Naturale	V2	175 mm <sup>3</sup> Average Value	<ul style="list-style-type: none"> <li>A Naturale</li> <li>B Soft (Road)</li> <li>C Soft (Openspace, Office, Loft)</li> </ul>	<ul style="list-style-type: none"> <li>1 Naturale</li> <li>2 Soft (Road)</li> <li>3 Soft (Openspace, Office, Loft)</li> </ul>	<b>20 YEARS</b> RESIDENTIAL Naturale PUBLIC Soft Road, Naturale	<b>10 YEARS</b> RESIDENTIAL Soft Openspace, Office, Loft PUBLIC Soft Road
-------------	----	--------------------------------------	---	---	---	---





LOFT NATURALE | 3,5mm | 100x100cm / 39"x39"



OVER

OPENSACE NATURALE | 3,5mm | 100x100cm / 39"x39"





# Soft

MATT AND SOFT. This matt and soft surface, which is so pleasant to touch, is obtained using diamond brushes with different grain sizes.







## THE LANGUAGE OF WOOD

---

Wood talks to our heart. The colour of fibre, the pattern of veins and the pleasure of touch are a direct and timeless language. The wood selected by Cotto d'Este and collected in two well-structured collections talks about life and relations to give shape to warm environments that are elegantly simple, in the balance between tradition and modernity.

NOCE RETT. |  5,5 mm | 33x300 cm 13" x118"





# FOREST

ESSENCE OF WOOD



ACERO



ROVERE



NOCE

FINISHING

**RECTIFIED**

THICKNESS



SIZES

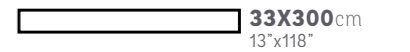

ROVERE RETT. | ➔ 5.5 mm | 20x180cm / 8"x71" - 20x120cm / 8"x48"

SLIP RESISTANCE



R10

DESHADING



V3 Acero, Noce  
V4 Rovere

DEEP ABRASION RESISTANCE



175 mm<sup>3</sup>  
Average Value

TREAD MARK VISIBILITY



A Noce  
B Acero, Rovere

CLEANING EASINESS



1 Noce  
2 Acero, Rovere

ANTIMICROBIAL SURFACE

**PROTECT**  
ANTIMICROBIAL

COTTO D'ESTE GUARANTEE



20 YEARS  
RESIDENTIAL AND PUBLIC











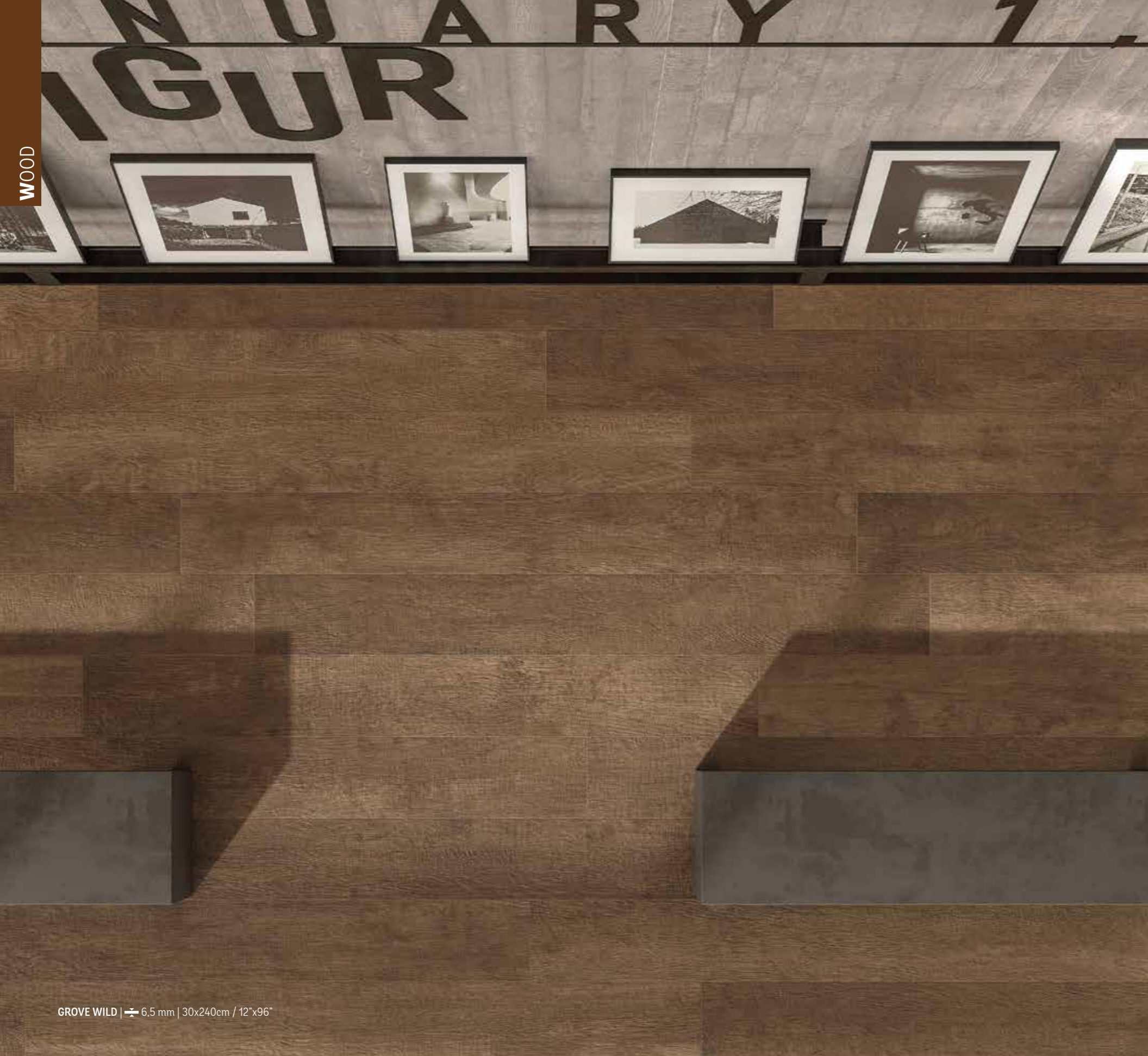

# WOODLAND

THE ELEGANCE OF NATURE



ATLANTIC SOFT BOREAL SOFT TROPICAL SOFT TEAK SOFT



EBONY SOFT ARDEN WILD GROVE WILD WALDEN WILD

FINISHING

**RECTIFIED**

THICKNESS

SURFACE

SIZES

**kerlite** 6plus **Soft Wild**

**30X240cm**  
12"x96"

**20X120cm**  
8"x48"

GROVE WILD | 6.5 mm | 30x240cm / 12"x96"

SLIP RESISTANCE

DESHADING

DEEP ABRASION RESISTANCE

TREAD MARK VISIBILITY

CLEANING EASINESS

ANTIMICROBIAL SURFACE

COTTO D'ESTE GUARANTEE



R9 SOFT  
R10 WILD



V2 SOFT  
V3 WILD



175 mm<sup>3</sup>  
Average Value



A



1

**PR( )TECT**  
ANTIMICROBIAL



20 YEARS  
RESIDENTIAL AND PUBLIC





TROPICAL SOFT | 6.5mm | 20x120cm / 8"x48"



EBONY SOFT | 6.5mm | 20x120cm / 8"x48"



ATLANTIC SOFT | 6.5mm | 30x240cm / 12"x96" - 20x120cm / 8"x48"





BOREAL SOFT | ➔ 6,5mm | 30x240cm / 12"x96"



TEAK SOFT | ➔ 6,5mm | 30x240cm / 12"x96"





WOODLAND

ARDEN WILD | 6,5mm | 30x240cm / 12"x96" | 20x120cm / 8"x48"



WALDEN WILD | 6,5mm | 30x240cm / 12"x96"





## RIGOUR AND ELEGANCE

---

The depth of black and the brightness of white; the realistic crude sheet effect of Iron and the intense rust-coloured Corten. Solid colours, elegant and authentic, alongside three metallic surfaces perfectly in keeping with the trends of contemporary architecture, highlighted by the large size and versatility of Kerlite.





ULTRAWHITE GLOSSY | 5.5 mm | 100x100 cm / 39"x39"





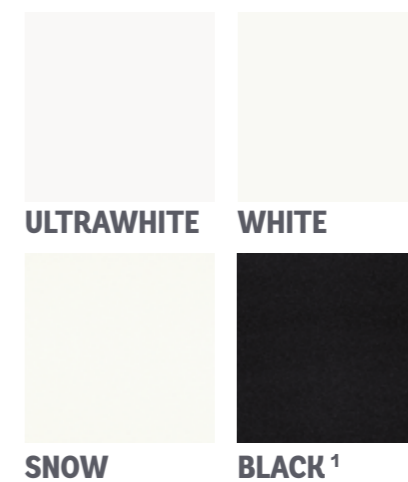





# BLACK-WHITE

ABSOLUTE STYLE



FINISHING

**RECTIFIED**

THICKNESS	SURFACE	SIZES
<b>kerlite</b> 3plus  		 <b>100X300cm</b> 39"x118" black, snow, white
		 <b>100X100cm</b> 39"x39" black, snow, white
		 <b>50X100cm</b> 19 1/2"x39" black, snow, white
<b>kerlite</b> 5plus  	<b>Glossy</b> Silk ( P )	 <b>100X300cm</b> 39"x118" black, ultrawhite
		 <b>100X100cm</b> 39"x39" black, ultrawhite
		 <b>50X100cm</b> 19 1/2"x39" black, ultrawhite

DESHADING

DEEP ABRASION RESISTANCE

TREAD MARK VISIBILITY

CLEANING EASINESS

ANTIMICROBIAL SURFACE

COTTO D'ESTE GUARANTEE

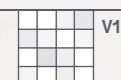

**PROTECT**  
ANTIMICROBIAL - 5plus



<sup>1</sup>BLACK GLOSSY - Residential Only









Floor: WHITE | ➔ 3,5mm | 100x100cm / 39"x39"  
Wall: WHITE | ➔ 3,5mm | 100x100cm / 39"x39"



ULTRAWHITE | ➔ 5,5mm | 100x100cm / 39"x39"

BLACK - WHITE



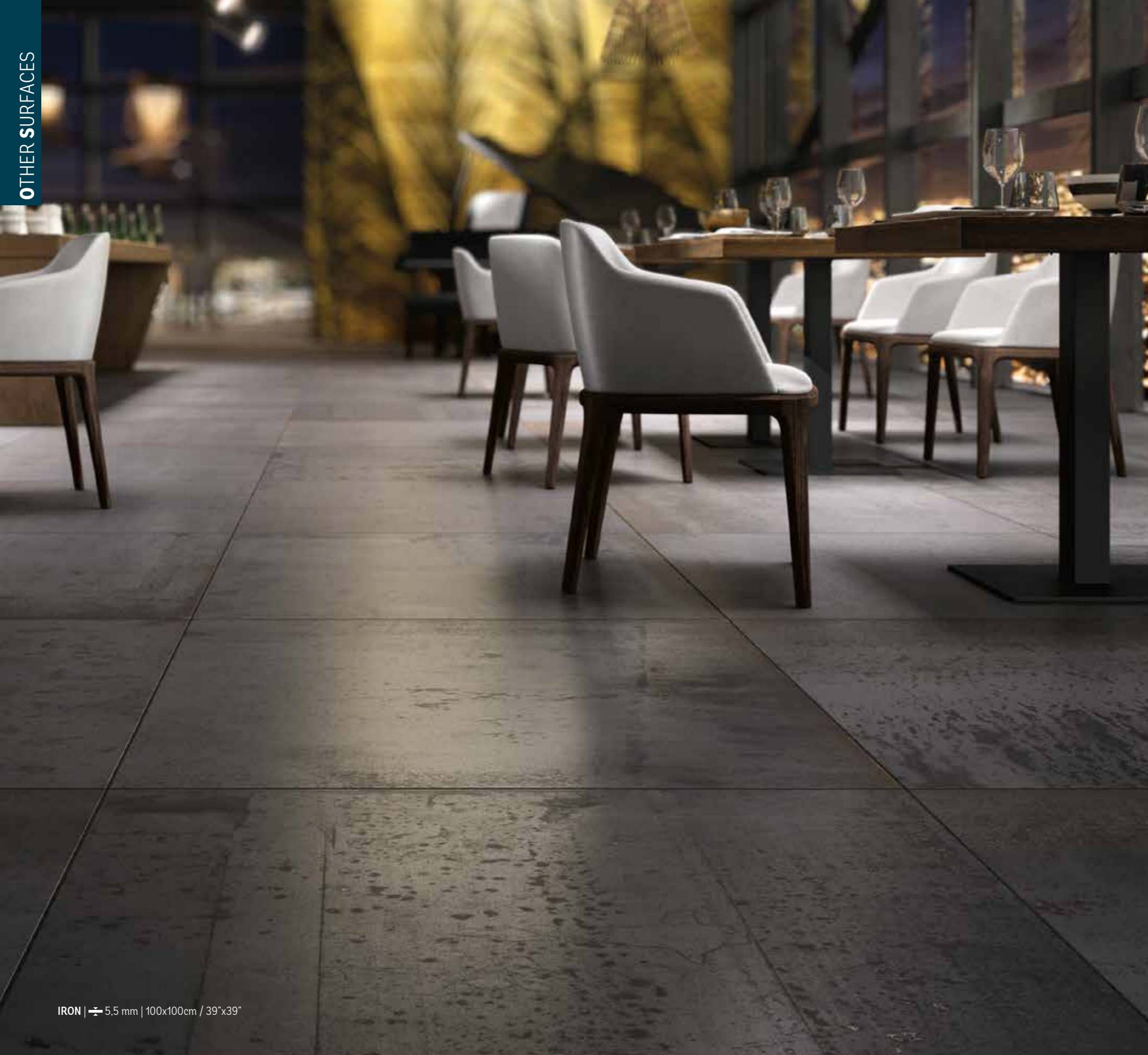

IRON | 5.5 mm | 100x100cm / 39"x39"

# METAL

METALLIC SLABS



CORTEN



IRON

FINISHING

**RECTIFIED**

THICKNESS



SIZES



SLIP RESISTANCE

DESHADING

DEEP ABRASION RESISTANCE

TREAD MARK VISIBILITY

CLEANING EASINESS

ANTIMICROBIAL SURFACE

COTTO D'ESTE GUARANTEE



R9 Corten



V2 Iron  
V3 Corten



175 mm<sup>3</sup>  
Average Value



A Iron  
B Corten



1 Iron  
2 Corten

**PROTECT**  
ANTIMICROBIAL



20 YEARS  
RESIDENTIAL



10 YEARS  
PUBLIC





CORTEN | 5,5mm | 100x300cm / 39"x118"



CORTEN | 5,5mm | 100x300cm / 39"x118"

METAL





Wall: VENICE | ± 3.5mm | 100x300cm / 39"x118"

# WONDERWALL

KERLITE ART

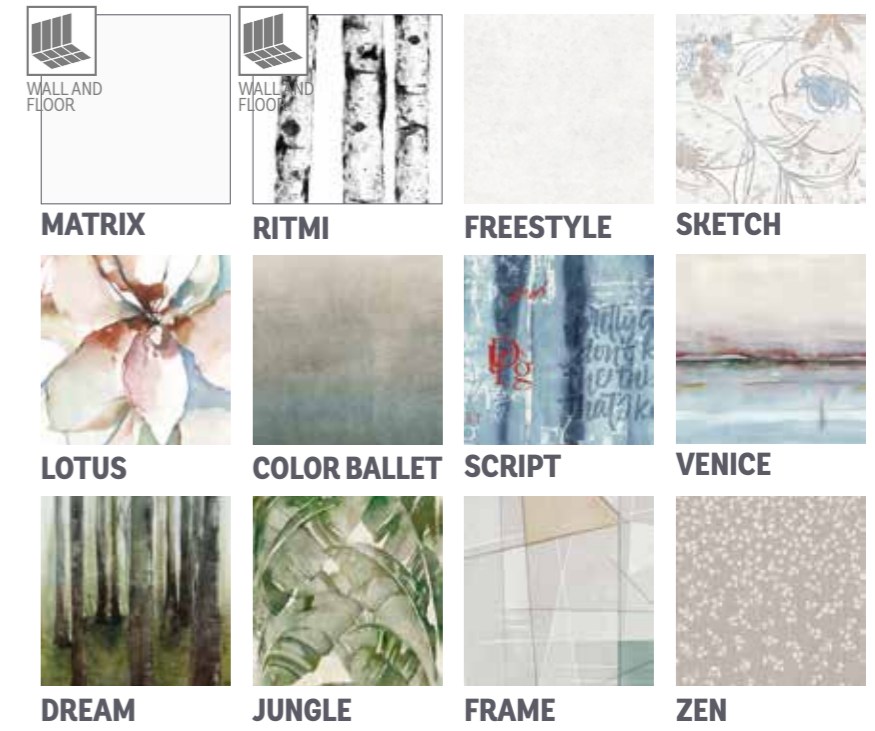

FINISHING  
**RECTIFIED**

THICKNESS



SIZES

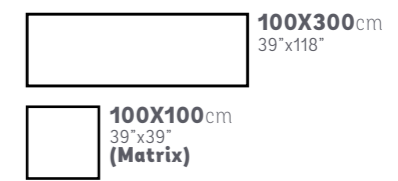

DESHADING    DEEP ABRASION RESISTANCE    TREAD MARK VISIBILITY    CLEANING EASINESS    ANTIMICROBIAL SURFACE

COTTO D'ESTE GUARANTEE

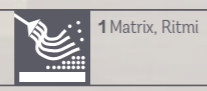





Wall: LOTUS - MATRIX | 3,5mm | 100x300cm / 39"x118"



Wall: DREAM | 3,5mm | 100x300cm / 39"x118"  
Floor: VANITY, BIANCO LUCE GLOSSY | 6,5mm | 120x120cm / 48"x48"



Wall: JUNGLE | 3,5mm | 100x300cm / 39"x118"  
Floor: VANITY, DARK BROWN GLOSSY | 6,5mm | 120x260cm / 48"x102"

WONDERWALL





Wall: ZEN | 3,5mm | 100x300cm / 39"x118"  
Floor: VANITY, DARK BROWN TOUCH | 6,5mm | 120x120cm / 48"x48"



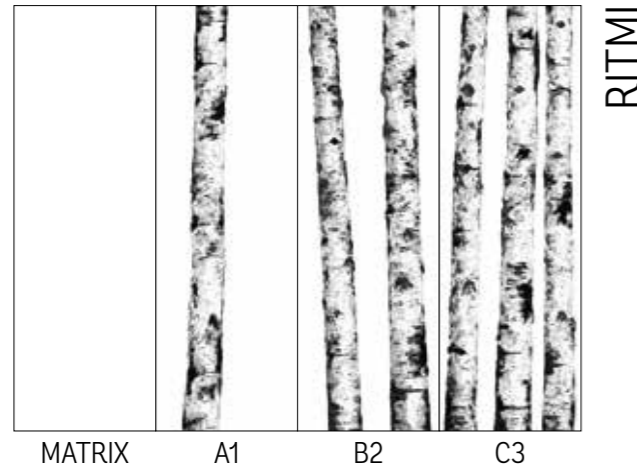

RITMI

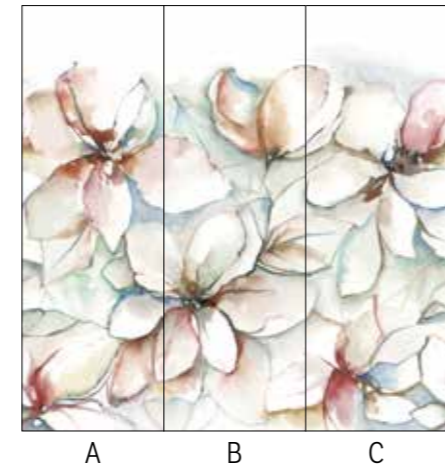

LOTUS

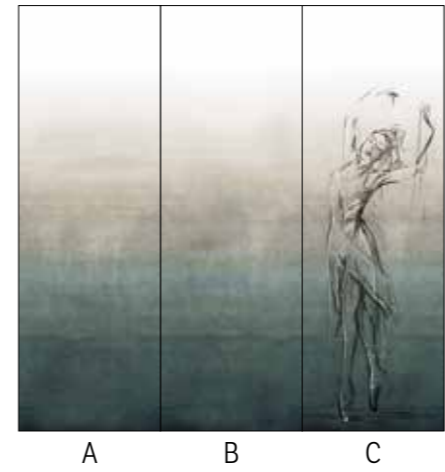

COLOR BALLETT

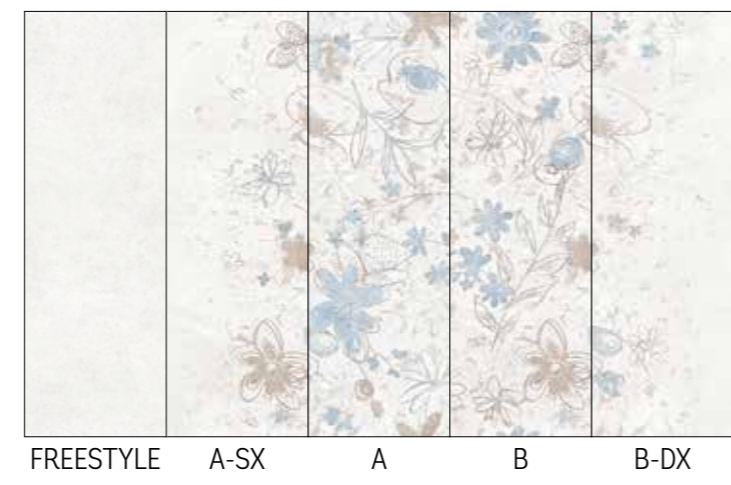

SKETCH

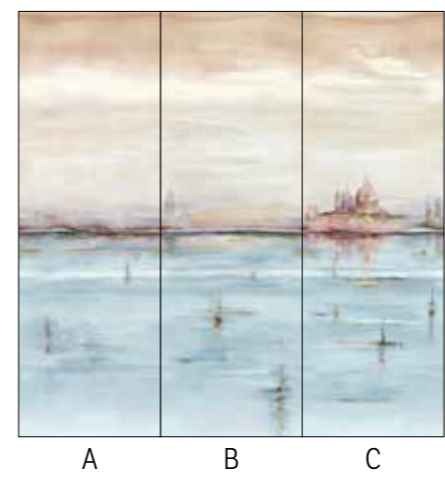

VENICE

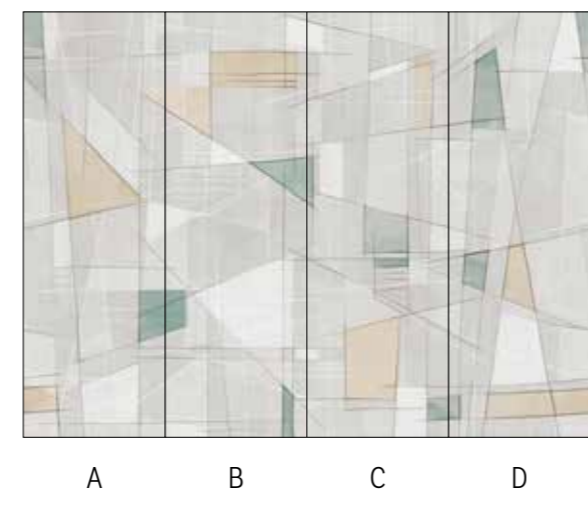

FRAME

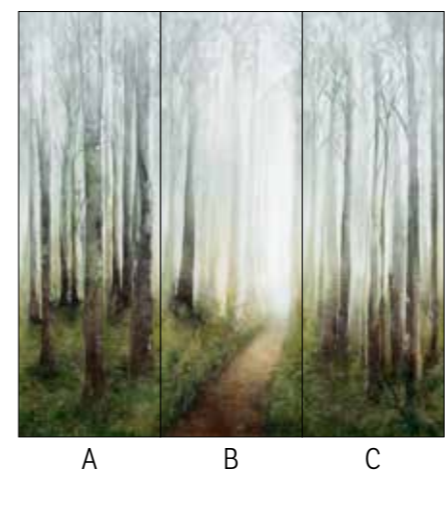

DREAM

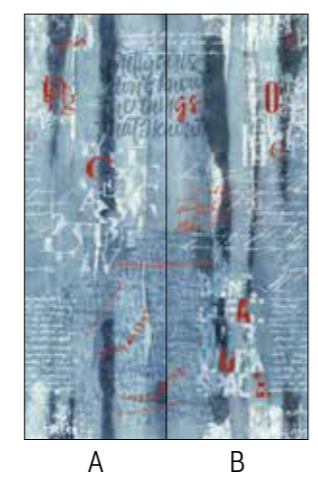

SCRIPT



ZEN

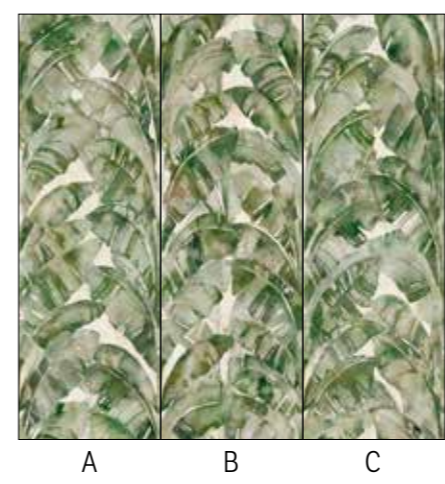

JUNGLE





# REFERENCES



## REARTH HEADQUARTER BUILDING

Year: 2019

Location: Bucheon - South Korea

Design: Bong Ki, Choi

Product: Kerlite Black-White Ultrawhite 100x300cm

Laying system: ventilated facade





## SIEMENS HEADQUARTER

Year: 2018  
Location: Milano (MI) - Italy  
Design: Barreca & La Varra (progetto architettonico),  
DEGW (interior design & space planning)  
Product: Kerlite Cluny Auvergne Layè  
Laying system: ventilated facade





# INTERNATIONAL BUSINESS CENTER

Year: 2010  
Location: Moscow - Russia  
Design: Zao Gorproject  
Product: Kerlite Exedra Travertino multisizes  
Laying system: ventilated facade





## REALE GROUP HEADQUARTERS

Year: 2016

Location: Torino (TO) - Italy

Design: Iotti + Pavarani Architetti

Product: custom made 100x300cm

Laying system: ventilated facade





**FASTWEB HEADQUARTER**

Year: 2018

Location: Milano (MI) - Italy

Design: Studio ACPV, Antonio Citterio, Patricia Viel

Product: Kerlite CLuny Argerot 100x300cm

Laying system: adhesive





**FLORENCE NEW OPERA HOUSE**

Year: 2011

Location: Firenze (FI) - Italy

Design: ABDR Architetti Associati

Product: custom made Kerlite Cipollino 50x150cm

Laying system: adhesive





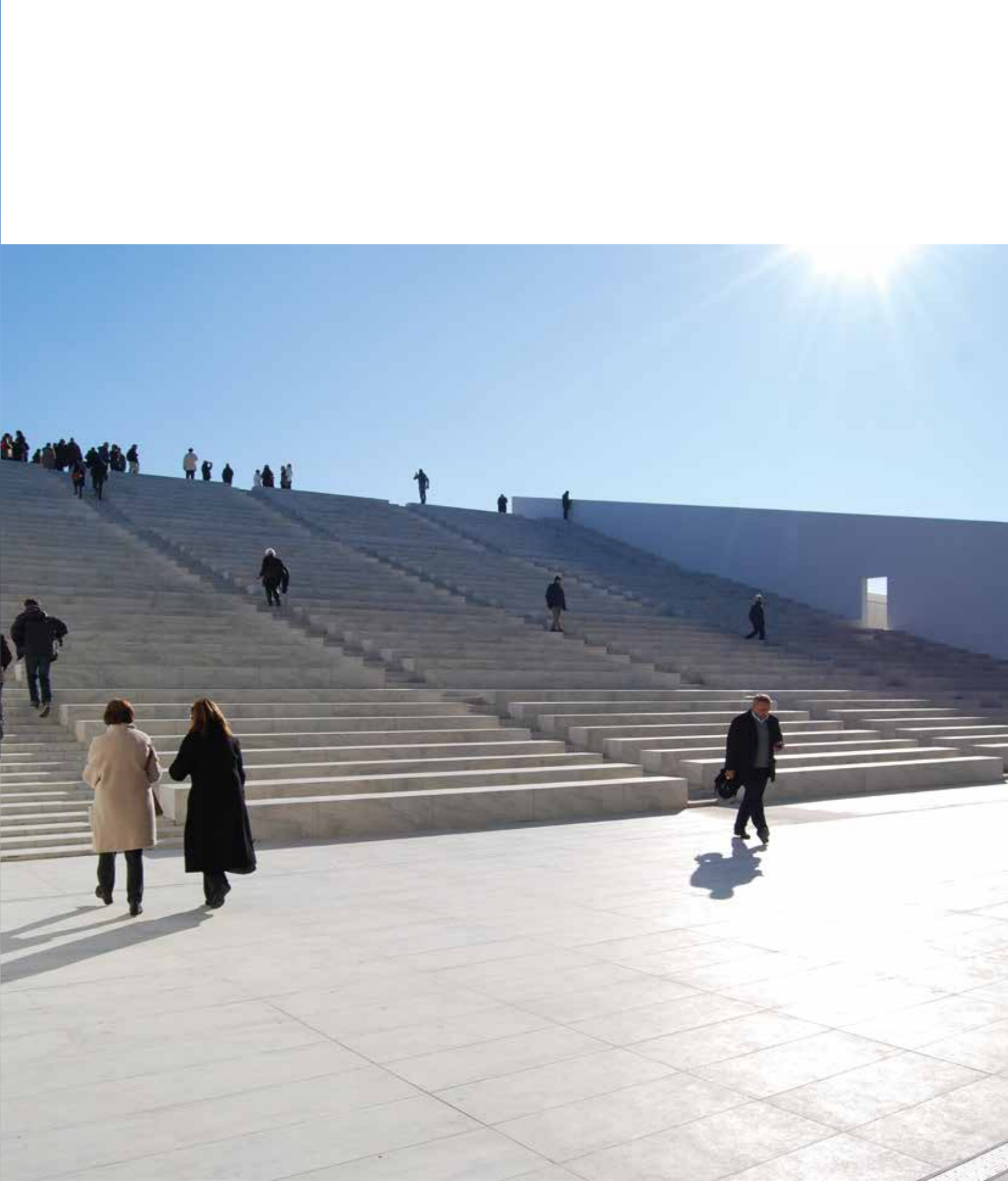



## PÉCS ZOO

Year: 2016  
Location: Pécs - Hungary  
Design: NARA STÚDIO  
Product: Kerlite Buxy Corail Blanc 100x300cm  
Laying system: adhesive





## HOTEL PANGEA & NYÍREGYHÁZA ZOO

Year: 2018

Location: Nyíregyháza - Hungary

Design: Attila Gáva, Gav-Art studio

Product: Kerlite Forest Rovere 100x300cm

Laying system: adhesive





**RESIDENCE LIDO RICCIO**

Year: 2017

Location: Ortona, Chieti (CH) - Italy

Design: Edgardo Toso Srl, Arch. Claudio Angelucci

Product: Kerlite Black-White Snow 5x100cm, 50x100cm

Laying system: ventilated facade

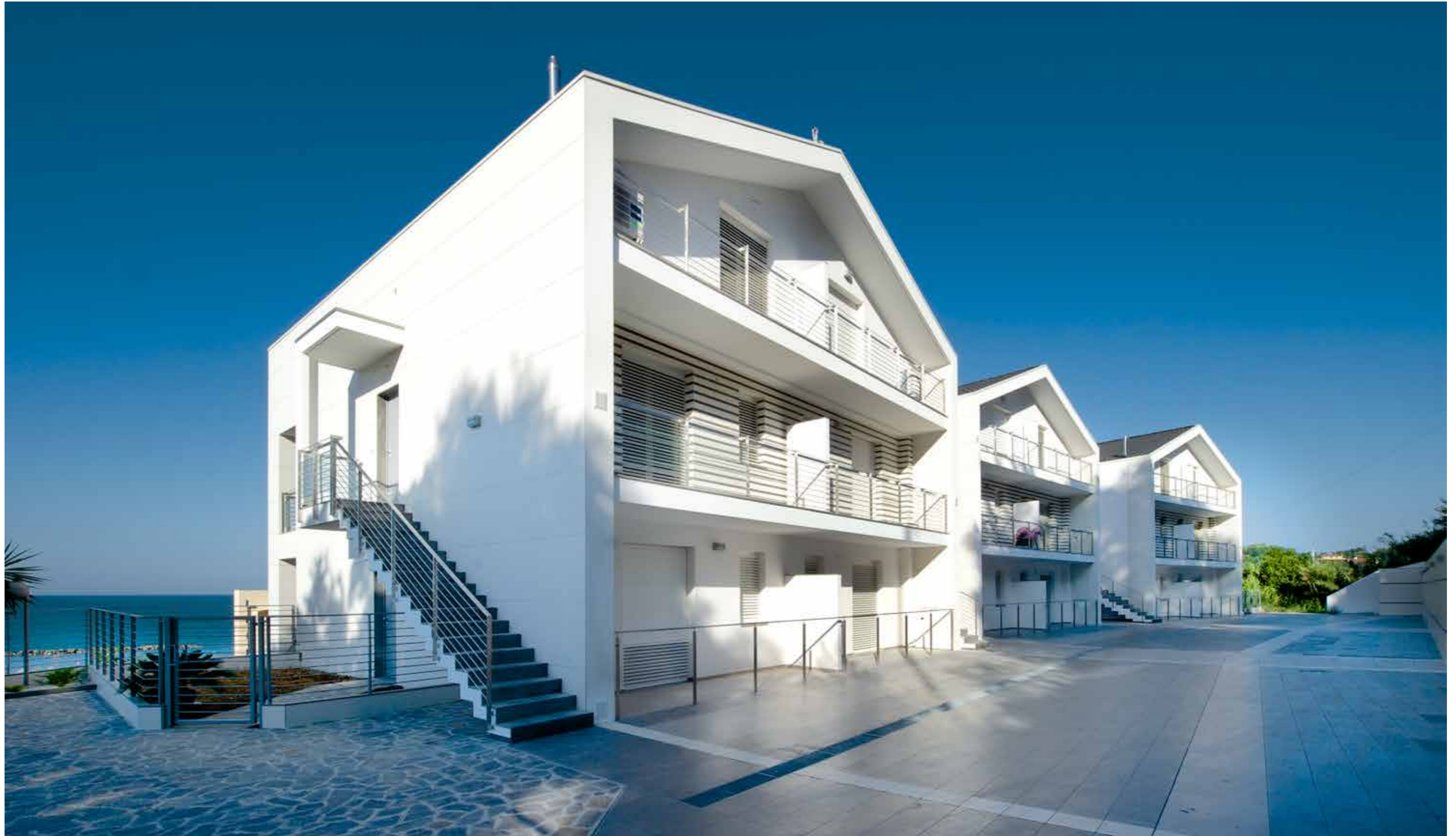



**PRIVATE HOUSE**

Year: 2015  
Location: Aversa (CA) - Italy  
Design: Studio di Architettura di Marino Giustino  
Product: Kerlite Elegance Via Farini/Via Condotti 40x100cm  
Laying system: ventilated facade





**CHONGQING WEST - RAILWAY STATION**

Year: 2018

Location: Chongqing - P.R. China

Design: China Railway Eryuan Engineering Group Co., Ltd

Product: Kerlite Exedra Travertino 100x300cm

Laying system: adhesive





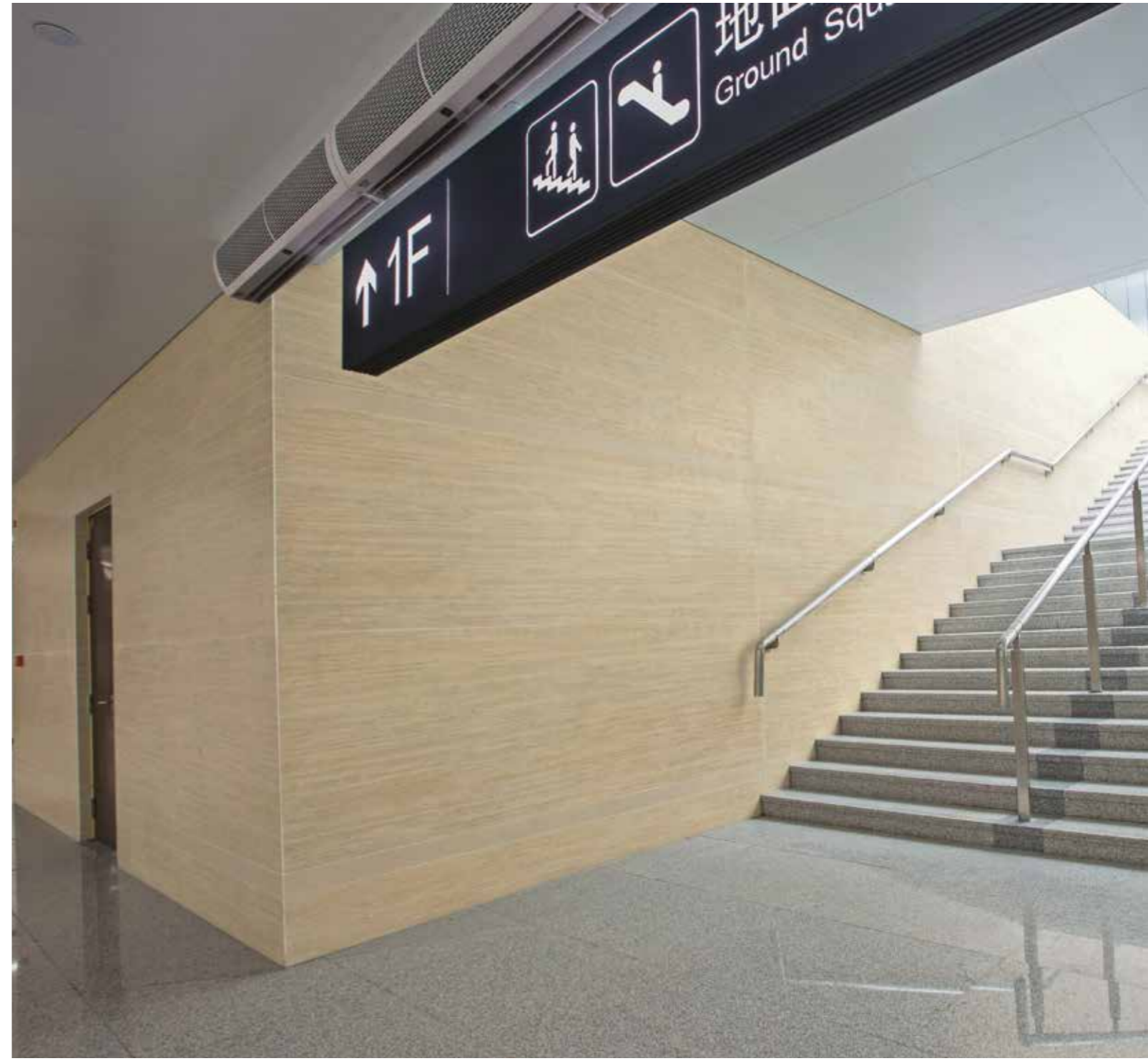



**SHANGHAI CAOHEJING HI-TECH PARK**

Year: 2018

Location: Shanghai - P.R. China

Design: Roberts Spaces SH

Product: Kerlite Exedra Calacatta silk 100x300cm

Laying system: adhesive





## UNIPOL TOWER

Year: 2012

Location: Bologna (BO) - Italy

Design: Open Project

Product: Kerlite Over Road/Office

Laying system: adhesive





## NEW HIGH-SPEED BOLOGNA CENTRAL STATION

Year: 2013  
Location: Bologna (BO) - Italy  
Design: Adrea Maffei Architects, Arata Isozaki & Associates,  
M+T & Partners, Arup Italia  
Product: Kerlite Over Office  
Laying system: adhesive





## NUMBER A1 VAR TUNNEL

Year: 2016  
Location: Badia Nuova (BO) - Aglio (FI) - Italy  
Technical supervision: Enrico Dal Negro, Alfredo Cullacciati,  
Mapei Utt and Arduino Mastropietro  
Product: Kerlite White A1 Plus  
Laying system: adhesive





**PRIVATE HOUSE**

Year: 2011

Location: Lama (TA) - Italy

Design: Arch. Paolo Avarello

Product: Kerlite Black-White Snow 100x300cm

Laying system: adhesive

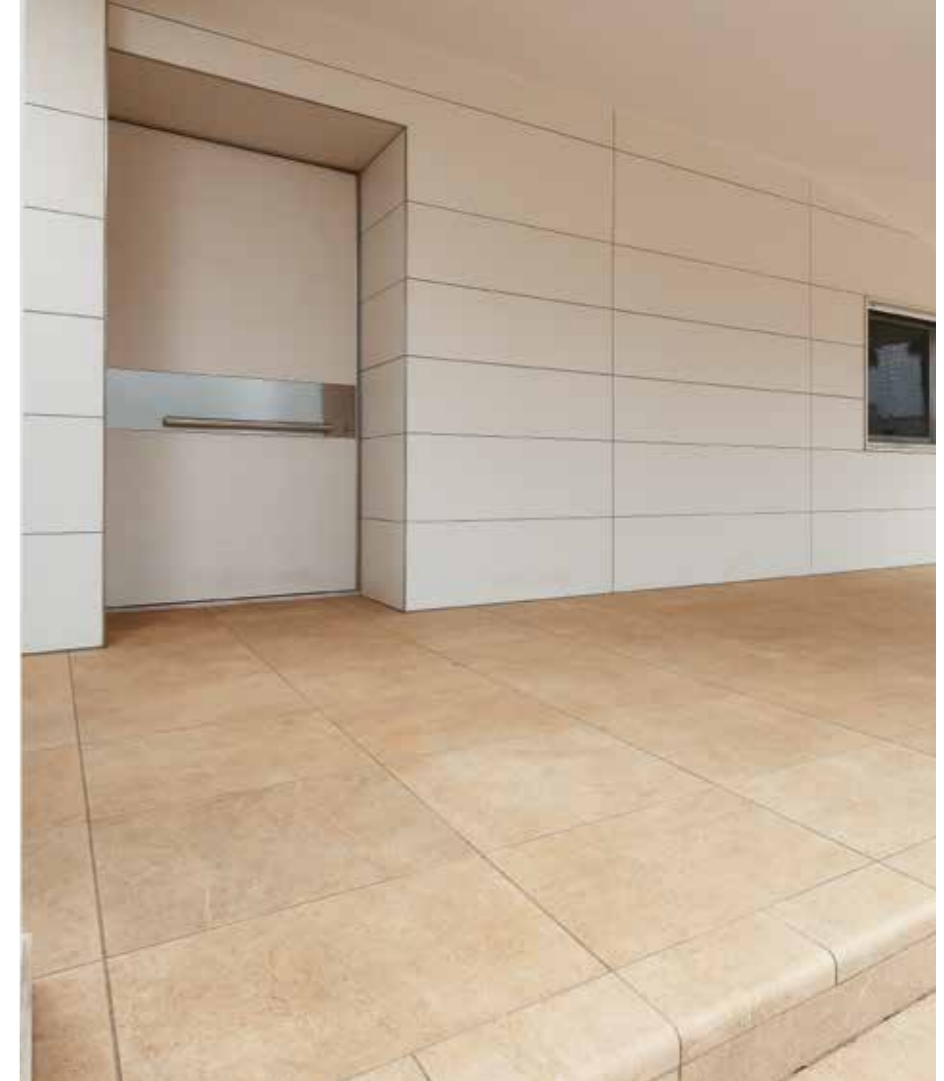



**PRIVATE HOUSE**

Year: 2012

Location: Zoagli (GE) - Italy

Design: Stefania Garibotto Architect, Chiara Viale Architect, Bruno Caroni Architect

Product: Kerlite Elegance Via Tornabuoni 100x100cm

Laying system: adhesive





# VENTILATED FACADE SYSTEM

## Ventilated facade with hidden anchors

### - LUNA SLOT SYSTEM

In partnership with DALLERA

#### Mechanical bonding

With slots on the horizontal edge of the tiles where the fixing hooks connected to the supporting structure are inserted

- Formats: up to 300x100 cm  
- Type: KERLITE double-layer



### - GEOS SYSTEM

In partnership with GEOS ITALY

#### Mechanical bonding

With slots at the back of the tile, in which metal profiles are inserted which fix the tile to the bearing structure

- Formats: up to 300x100 cm  
- Type: KERLITE 5PLUS



### - PROGEST SYSTEM

In partnership with PROGEST

#### Structurally adhered bonding

By structurally binding metal profiles on the back of the tiles, which are then secured mechanically to the bearing structure

- Formats: up to 300x100 cm  
- Type: KERLITE 5PLUS



### - LUNA VISTA SYSTEM

In partnership with DALLERA

#### Mechanical bonding

With camouflaged hooks on the horizontal edge of the tiles, used to fix the tiles to the supporting structure

- Formats: up to 300x100 cm  
- Type: KERLITE 3PLUS - 5PLUS



### - VENERE SORMONTATO SYSTEM

In partnership with DALLERA

#### Mechanical bonding

With camouflaged hooks on the horizontal edge of the overlapping tiles, used to fix the tiles to the supporting structure

Formats: up to 300x50 cm  
- Type: KERLITE 3PLUS - 5PLUS



### - SIRIO SYSTEM

In partnership with DALLERA

#### Mechanical bonding

With holes drilled through the tiles in which camouflaged bolts are inserted and screwed to the bearing structure

- Formats: up to 300x100 cm  
- Type: KERLITE 3PLUS - 5PLUS







TODAY  
RENOVATING  
IS EASIER





# WHAT IS IT

It is the first dry laying installation system without the use of adhesives CERTIFIED with KERLITE, superior quality ultra-thin ceramic slabs.

With a thickness of only 7 mm, this system is used for the installation of a new kind of highly durable porcelain stoneware flooring that is perfect for interior RESIDENTIAL or LIGHT COMMERCIAL use.

It is possible to renovate without demolishing as it can be laid on pre-existing floors.

**KERLITE EASY is unique, because it uses a high-performance product: laminated porcelain stoneware Kerlite slabs, exactly as they are when they exit the production line.**

**This means no subsequent processing and the guarantee of a quality manufacturing process tested by Cotto d'Este in over 15 years of experience and with millions of square meters sold worldwide.**

# ASSEMBLING THE SYSTEM

**1 Silent**  
SOUNDPROOFING MAT



**Unroll and extend the base mat**

After verifying that the subfloor is clean and level, proceed with laying the SILENT soundproofing mat on the entire floor area.

**2** Kerlite 6plus THIN PORCELAIN STONEWARE Kerlite 5plus THIN PORCELAIN STONEWARE

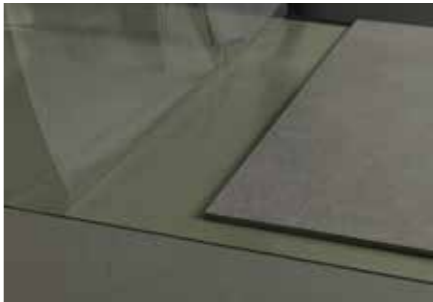

**Lay the Kerlite slabs**

Then lay the Kerlite slabs, chosen among the colours available in the 5plus and 6plus versions, directly on the mat without the use of adhesives. Use 2mm spacers to maintain the space between the slabs constant.

**3 Filler**  
FINISHING SEALANT



**Seal the grout lines**

After having laid KERLITE on the floor, it is necessary to seal the spaces between the slabs with FILLER. Once dry, this sealant guarantees a perfect walkable and waterproof surface.





## PRIMARY INTENDED USE



Homes



Light Commercial Spaces



Trade Show Stands



Temporary Shops

## WHO IS IT FOR

### Retailers of ceramic materials

To create new sales opportunities with both business to business clients and end-users.

### Installers

To have access to a new high-quality solution when it is necessary to work quickly, using a product with high aesthetic value. KERLITE EASY is the perfect system with which to preserve, if necessary, the underlying floor.

### Designers

To offer clients a high quality solution when they need a job done quickly, using a range that provides the utmost aesthetic value. KERLITE EASY is the perfect system for preserving, when necessary, the old underlying floor.

### End-user

To have a new and highly attractive floor in very little time, without the inconvenience of demolishing the old floor, thus significantly reducing the costs of installation and without having to raise the doors. This solution also significantly reduces impact and footfall noise towards the lower floor.

## AN OUTSTANDING SOLUTION



### SUPERIOR DURABILITY

**The secret of KERLITE EASY is Kerlite.**

Because only with Kerlite does the system guarantee the utmost reliability. Tests conducted on flooring created with the KERLITE EASY system have shown that the combination of the SILENT mat and the compactness of KERLITE combined to its fibreglass reinforcement provide a degree of durability that is superior to the standards offered by ordinary flooring with adhered ceramic tiles.

**All of this is further enhanced by the exclusive benefit of a drastic reduction in footfall noise.**

## ITS EXCLUSIVE BENEFITS

### Stable

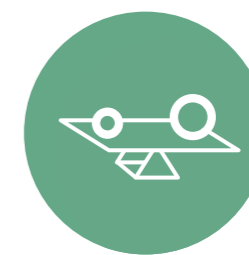

The fibreglass mesh on the reverse side of Kerlite slabs combined with the use of the SILENT mat and the FILLER sealant ensure the utmost resistance and stability to the floor.

### Easy



KERLITE EASY uses a new laying method for ceramic tiles which is a consolidated system that is already commonly used for other laminated products.

### Waterproof



With the combined use of Kerlite slabs and FILLER sealant, the floor is guaranteed to be entirely waterproof.





**Lightweight**

With a weight of only 13 kg/m<sup>2</sup> one can have a new porcelain stoneware floor without weighing down the existing structure.



**Practical**

Makes it possible to create an overlying ceramic surface without demolishing the old floor.



**Affordable**

Provides significant savings as compared to a standard renovation.



**Fast**

It is straightforward and quick to install.



**Silent**

It is soundproof: thanks to the combined action of the SILENT mat and Kerlite.

**It reduces footfall noise to the lower floor by approximately 16 times more than ordinary adhered ceramic tile floors.**



**Certified**

Compliant with the strict American standard for flooring ASTM C627 (ROBINSON TEST).



**More Attractive**

Makes it possible to create a floor without expansion joints.



**Environmentally Sustainable**

Makes it possible to periodically replace the materials and reuse them in other environments.



**SUPERIOR QUALITY THIN CERAMIC SLABS**

**Large-sized laminated porcelain stoneware reinforced with fibreglass:**

a light, resistant and versatile product for new design perspectives in the world of architecture and housing.

**Highest standards in quality and performance**

Thanks to the use of the best raw materials

**Highly compact and elastic slabs**

Thanks to a unique pressing process

**Excellent aesthetic look of the products**

Thanks to exclusive surface processing technologies

**Extraordinary added resistance**

Thanks to the reinforcing fibreglass mesh

**Highly eco-friendly**

Less raw materials used, lower water and energy consumption and lower CO<sub>2</sub> emissions

In a complete range of over 140 articles

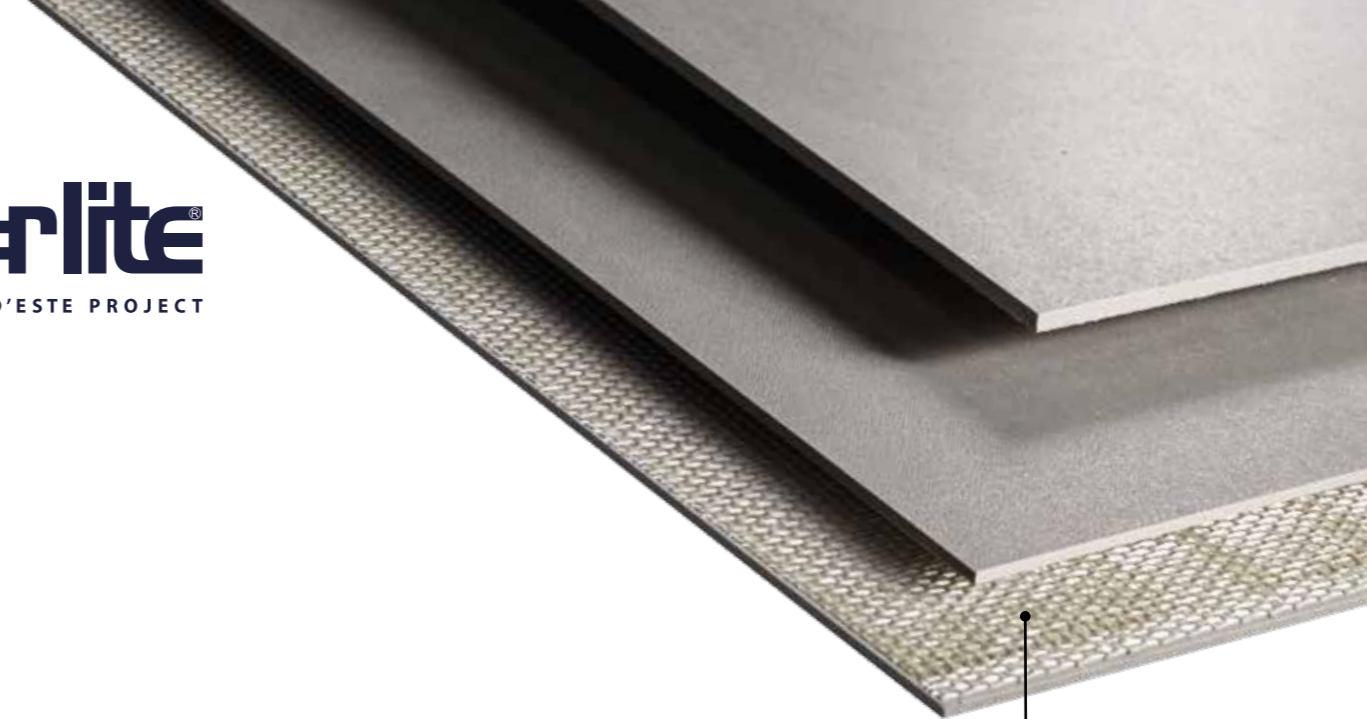
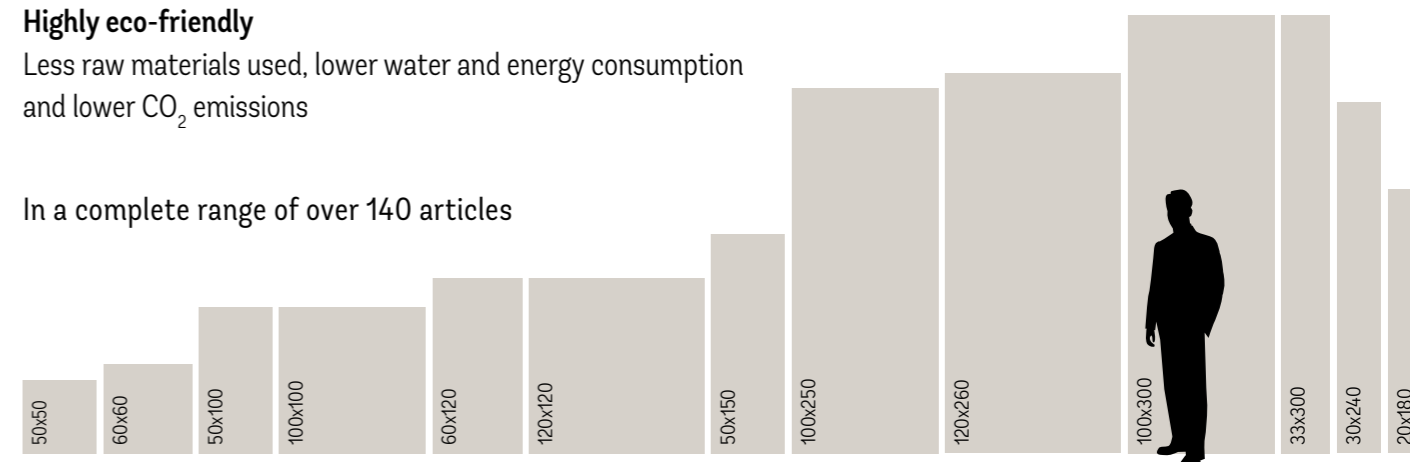



# TECHNICAL CHARACTERISTICS

## SLIP RESISTANCE



### DIN 51130

In this test, an operator stands on a surface covered with tiles for testing. The surface, initially horizontal, is gradually tilted until the moment when the operator starts to slip. The angle of tilt of the surface when slipping starts provides the rating.

- $\alpha < 6^\circ$  = not classified
- $6^\circ \leq \alpha \leq 10^\circ$  = R9
- $10^\circ < \alpha \leq 19^\circ$  = R10
- $19^\circ < \alpha \leq 27^\circ$  = R11
- $27^\circ < \alpha \leq 35^\circ$  = R12
- $\alpha > 35^\circ$  = R13

### DIN 51097

The method aims to measure the tiles' suitability for laying in locations where people walk barefoot (e.g. edges of swimming-pools, showers, etc.). An operator walks barefoot over a tilting surface laid with the tiles for testing, wet with a soap and water solution. The surface is gradually tilted and the angle of tilt at which the operator starts to slip provides the tiles' rating, as shown in the table below.

$\alpha < 12^\circ$	not classified
$12^\circ \leq \alpha < 18^\circ$	A
$18^\circ \leq \alpha < 24^\circ$	B (A+B)
$\alpha \geq 24^\circ$	C (A+B+C)

### ANSI A326.3

**Dynamic Coefficient of Friction (DCOF):** Sometimes called kinetic coefficient of friction. This is the ratio of the force necessary to keep a surface already in motion sliding over another divided by the weight (or normal force) of an object. This force is a materials property of the two surfaces. DCOF is usually less than SCOF for the same materials. Contaminants such as dirt, water, soap, oil, or grease can change this value.

Unless otherwise specified, tiles suitable for interior spaces expected to be walked upon when wet shall have a wet DCOF of 0.42 or greater when tested using SLS solution. However, tiles with a DCOF of 0.42 or greater are not necessarily suitable for all projects. The specifier shall determine tiles appropriate for specific project conditions, considering by way of example, but not in limitation, type of use, traffic, expected contaminants, expected maintenance, expected wear, and manufacturers' guidelines and recommendations.

### BCRA TORTUS

English method for determining the coefficient of friction of surfaces based on the resistance opposed to the movement of a tester instrument (Tortus) that traverses the surface to be tested. The method is based on the use of a mobile device to determine the coefficient of friction that standard materials, such as rubber and leather, have in wet or dry conditions further to contact with a certain floor covering material. As explained above, the "Tortus test" is the reference method for National legislation under paragraph 8.2.2 of Ministerial Decree 236/89, which envisages a coefficient equal to >0.40 in dry Dry Rubber and Wet Leather conditions. The friction coefficient testing machine for wet surfaces is the Digital Sliptester Floor Slide Control FSC 2000 system, which is computer-controlled.

$\leq 0,20 \mu$	Dangerous sliding
$0,20 \div 0,40 \mu$	Excessive sliding
$0,40 \div 0,75 \mu$	Satisfaction friction
$\geq 0,75 \mu$	Excellent friction

## BREAKING STRENGTH (S)



### ISO 10545-4

This parameter is used to assess the ceramic tile's capacity to withstand static and dynamic loads after laying. The standard considers the tile as a beam, placed on two rollers some distance apart, while a third roller applies a force to its centre. The breaking strength is the weight the tile withstands before breaking. The actual breaking strength of a tile after laying is considerably higher than the value measured in the laboratory.

### ASTM C 648

The test method consists of supporting the tile on the ends of three cylindrical rods, or on three ball bearings for tiles having a facial area of 6.25 in<sup>2</sup> (40 cm<sup>2</sup>) or less, arranged in an equilateral triangle, and applying force at a definite rate to the centre of the triangular support, until the specimen breaks.



**STAIN RESISTANCE**



**ISO 10545-14**

The operating surface is subject to three staining agents, olive oil, iodine alcohol solution and chromium green in light oil; after 24 hours the surface is cleaned.

**Class 5** - stain removed with warm water running for 5 minutes;

**Class 4** - stain removed by manual cleaning with mild detergent;

**Class 3** - stain removed by mechanical cleaning with strong detergent;

**Class 2** - stain removed by dipping in suitable thinner for 24 hours;

**Class 1** - stain not removed.

**RESISTANCE TO CHEMICAL ETCHING**



**ISO 10545-13**

The method measures the chemical resistance of both glazed (GL) and unglazed (UGL) tiles, using acids (hydrochloric, citric and lactic) and bases (potassium hydroxide) at low (L) and high (H) concentration. The classification is as follows:

**DEEP ABRASION RESISTANCE**

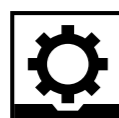

**ISO 10545-6**

Unglazed (UGL) surfaces are subjected to the deep abrasion method; this test measures the value of material removed from the surface with an abrasive disc after 150 rotations cycles. The lower the volume removed, the more resistant the material.

**WATER ABSORPTION**



**ISO 10545-3**

A ceramic material's capacity to absorb water depends on its porosity.

Thanks to the choice quality raw materials used and the state-of-the-art production technologies, Cotto d'Este products are always outstandingly compact, meaning that their porosity values are minimal.

The value expresses the percentage water absorption by weight.

**FROST RESISTANCE**



**ISO 10545-12**

Ceramic materials laid outdoors suffer frost damage if their porosity is above a certain level. When any water absorbed freezes, it increases in volume, generating strong internal mechanical stresses which may cause the material to detach from the underlying surface.

Cotto d'Este tiles are frostproof because, thanks to their porosity value of virtually nil, they always pass the ISO 10545-12 test comprising 100 freeze/thaw cycles between -5°C and +5°C without suffering any damage.

**DIFFERENCES IN TONE**

**ANSI A137.3**

**Aesthetic classification and shade variations.** Tiles may vary in color, texture, or appearance according to the manufacturer's design for that particular tile series or product line. The following aesthetic class designations have been provided in the Table, so that the manufacturer may communicate the aesthetic characteristics of a particular tile product.

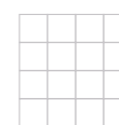

**V0**

NONE

**Very uniform appearance.**

Pieces of the same shade value are very uniform.

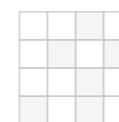

**V1**

MINOR

**Uniform appearance.**

Differences among pieces from the same production run are minimal.

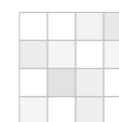

**V2**

LOW

**Slight variation.**

Clearly distinguishable differences in texture and/or pattern within similar colors.

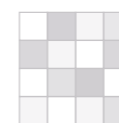

**V3**

MEDIUM

**Moderate variation.**

While the colors and or texture present on a single piece of tile will be indicative of the colors and or texture to be expected on the other tiles, the amount of colors and or texture on each piece may vary significantly. It is recommended that the range be viewed before selection.

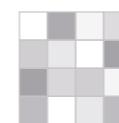

**V4**

MAJOR

**Substantial variation.**

Random color and or texture differences from tile to tile, so that one tile may have totally different colors and or texture from that on other tiles. Thus, the final installation will be unique. It is recommended that the range be viewed before selection.

**TREAD MARK VISIBILITY**

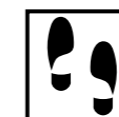

Cotto d'Este Method

This classification specifies the visibility degree of the tread marks left on the floor after walking with shoes dirty of dust.

**A** - Tread mark not visible

**B** - Tread mark not very visible.

**C** - Tread mark very visible.

Ideal for wall installation and recommended for floor installation in residential areas only.

**CLEANING EASINESS**



Cotto d'Este Method

The method consists in classifying the easiness grade in removing general dirt by manual cleaning with mild detergent.

**Grade 1**

Very easy, no resistance of the dirt, immediate removal.

**Grade 2**

Easy, light resistance of the dirt, fast removal.

**Grade 3**

Less easy, higher resistance of the dirt, slow removal. A strong detergent is recommended. Ideal for wall installation and recommended for floor installation in residential areas only.



# TECHNICAL CHARACTERISTICS



## SLIP RESISTANCE

According to:  
 ISO 13006-G (Gruppo Bla)  
 EN 14411-G (Gruppo Bla)  
 ANSI A137.3 (Back layered gauged porcelain slabs)

Kerlite 3plus Laminated porcelain stoneware Thickness 3,5 mm		DIN 51130	DIN 51097	ANSI A326.3	BCR TORTUS	UNE ENV 12633	BS 7976-2
BLACK-WHITE (Bla UGL)	Naturale						
BUXY (Bla UGL)		R10				Class 1	
CLUNY (Bla UGL)	Naturale	R9		DCOF ≥ 0.42	μ > 0,40	Class 1	
OVER (Bla UGL)	Naturale						
	Soft <sup>1</sup>						
WONDERWALL (Bla UGL) <sup>2</sup>	Matrix - Ritmi						
WONDERWALL (Bla GL) <sup>3</sup>	Freestyle - Sketch - Lotus - Script Jungle - Frame - Zen Venice - Color Ballet - Dream						

Kerlite Laminated porcelain stoneware Thickness 5,5 mm		DIN 51130	DIN 51097	ANSI A326.3	BCR TORTUS	UNE ENV 12633	BS 7976-2
BLACK-WHITE (Bla UGL)	Silk - Glossy <sup>4</sup>						
CEMENT PROJECT (Bla UGL)	Work - Cem	R9 Cem - R10 Work				Class 1 Work	
CLUNY (Bla UGL)	Layé	R10	B (A+B)	DCOF ≥ 0.42	μ > 0,40	Class 1	
ELEGANCE (Bla UGL)	Silk						
EXEDRA (Bla UGL)	Glossy <sup>4</sup>						
	Silk						
FOREST (Bla UGL)		R10	B (A+B)	DCOF ≥ 0.42	μ > 0,40	Class 1	
LIMESTONE (Bla UGL)	Natural					Class 2	PTV 36+ Wet (Sl 96)
MATERICA (Bla UGL)		R9					
METAL (Bla UGL)		R9 Corten			μ > 0,40 Corten		

Kerlite Laminated porcelain stoneware Thickness 6,5 mm		DIN 51130	DIN 51097	ANSI A326.3	BCR TORTUS	UNE ENV 12633	BS 7976-2
LITHOS (Bla UGL)	Naturale	R10		DCOF ≥ 0.42	μ > 0,40	Class 2	
	Soft					Class 1	
PIETRA D'ISEO (Bla UGL)	Naturale	R10		DCOF ≥ 0.42	μ > 0,40	Class 1	
VANITY (Bla UGL)	Glossy/Touch						
WOODLAND (Bla UGL)	Soft/Wild	R9 Soft - R10 Wild	B (A+B) Wild	DCOF ≥ 0.42	μ > 0,40	Class 1 Soft Class 2 Wild	

<sup>1</sup> Ideal for wall installation and recommended for floor installation in residential areas only.  
<sup>2</sup> Sintered and printed using ink-jet decorations.  
<sup>3</sup> Decorated using a new cold digital printing technology on Kerlite 3plus. Intended exclusively for the cladding of interior walls; do not use as flooring or to clad exterior spaces.  
<sup>4</sup> The sporadic presence of small non-uniformities or dots on the surface is to be considered characteristic of the material and of its finishing.

	DESCHADING	STAIN RESISTANCE	RESISTANCE TO CHEMICAL ETCHING ***	DEEP ABRASION RESISTANCE Average value	BREAKING STRENGTH (S) Average value	BENDING STRENGTH Average value	WATER ABSORPTION Average value ****	FROST RESISTANCE			
	ANSI A137.3	ASTM C 1378	ISO 10545-14	ASTM C 650	ISO 10545-13	ASTM C 1243 ISO 10545-6	ASTM C 1505	ISO 10545-14	ASTM C 373 ISO 10545-3	ASTM C 1026 ISO 10545-12	
V1		CLASS A RESISTANT	5 RESISTENTE RESISTANT	CLASS A RESISTANT	LA-HA RESISTENTE RESISTANT	CONFORME COMPLIANT					
V2		CLASS C	≥ 3				≥ 85 lbf	≥ 6.000 PSI	50 N/mm <sup>2</sup>	0,1%	RESISTENTE RESISTANT
V1		CLASS A RESISTANT	5 RESISTENTE RESISTANT	CLASS C	LA-HB	**					
V1		CLASS C Glossy	≥ 3 Glossy	CLASS C Glossy	LB-HB Glossy						
V2		CLASS A RESISTANT	5 RESISTENTE RESISTANT	CLASS A RESISTANT	LA-HA RESISTENTE RESISTANT	CONFORME COMPLIANT	≥ 175 lbf	≥ 6.000 PSI	50 N/mm <sup>2</sup>	0,1%	RESISTENTE RESISTANT
		CLASS C	≥ 3	CLASS C	LB-HB						
V3 Acero, Noce V4 Cembro, Rovere		CLASS A RESISTANT	5 RESISTENTE RESISTANT	CLASS A RESISTANT	LA-HA RESISTENTE RESISTANT						
V2		CLASS A RESISTANT	5 RESISTENTE RESISTANT	CLASS A RESISTANT	LA-HA RESISTENTE RESISTANT						
V1											
V2 Iron V3 Corten		CLASS A RESISTANT	5 RESISTENTE RESISTANT	CLASS A RESISTANT	LA-HA RESISTENTE RESISTANT	CONFORME COMPLIANT	≥ 175 lbf	≥ 6.000 PSI	50 N/mm <sup>2</sup>	0,1%	RESISTENTE RESISTANT
V2		CLASS A RESISTANT	5 RESISTENTE RESISTANT	CLASS A RESISTANT	LA-HA RESISTENTE RESISTANT						
		CLASS C	≥ 3	CLASS C	LB-HB						
V2 Soft - V3 Wild		CLASS A RESISTANT	5 RESISTENTE RESISTANT	CLASS A RESISTANT	LA-HA RESISTENTE RESISTANT	CONFORME COMPLIANT	≥ 175 lbf	≥ 6.000 PSI	50 N/mm <sup>2</sup>	0,1%	RESISTENTE RESISTANT

\* Class-5 resistance to food and beverage stains. Not resistant to iodine dye, methylene blue, or permanent marker.  
 \*\* This product's decoration is not scratch resistant to hard, sharp objects such as metal, stone, glass, and stoneware. Be extremely careful when handling the product during installation, making sure not to bump or slide tools or other sharp objects against the surface.  
 \*\*\* Excluding hydrofluoric acid and derivatives.  
 \*\*\*\* Average refers to ceramic material.



# TECHNICAL CHARACTERISTICS

According to: ISO 13006-G (Gruppo Bia) EN 14411-G (Gruppo Bia) ANSI A137.3 (Back layered gauged porcelain slabs)	FIRE REACTION		PROTECT ANTIMICROBIAL ANTIMICROBIAL SURFACE		INFORMATION ABOUT CLEANING	
	EN 13823	EN 9239-1	FLAME SPREAD ASTM E84		TREAD MARK VISIBILITY Cotto d'Este method	CLEANING EASINESS Cotto d'Este method

**Kerlite** Laminated porcelain stoneware Thickness 3,5 mm

BLACK-WHITE		Class A2-s1, d0 (WALL)	Class A2 <sub>fl</sub> -s1 (FLOOR)	Class A	B	2
BUXY					A Caramel, Perle, Noisette, Cendre B Corail Blanc, Amande	1
CLUNY	Naturale				B	2
OVER	Naturale				A	1
OVER	Soft				B Road C Openspace, Loft, Office	2 Road 3 Openspace, Loft, Office
WONDERWALL	Matrix - Ritmi		A	1		
WONDERWALL	Freestyle - Sketch - Lotus Script - Jungle Frame - Zen - Venice Color Ballet - Dream		Use water or generic neutral detergents or degreasers available over the counter in general stores. Do not use alcohol, acetone, or solvents in general.			

**Kerlite** Laminated porcelain stoneware Thickness 5,5 mm

BLACK-WHITE	Glossy - Silk	Class A2-s1, d0 (WALL)	Class A2 <sub>fl</sub> -s1 (FLOOR)	Class A	B	2	
CEMENT PROJECT	Work					A Color 10, 20, 30, 40 B Color 00, 30, 40	1 Color 10, 20, 30, 40 2 Color 00, 30, 40
	Cem						
CLUNY	Layé					B	2
ELEGANCE	Silk					A V.Tornabuoni, V.Farini B V.Condotti, V.Montenepoleone	1 V.Tornabuoni, V.Farini 2 V.Condotti, V.Montenepoleone
EXEDRA	Glossy - Silk					B	2
FOREST						A Noce, Cembro B Acero, Rovere	1 Noce, Cembro 2 Acero, Rovere
LIMESTONE	Natural					B	2
MATERICA						B Ardesia C Bianco, Avorio, Tortora	
METAL						A Iron B Corten	1 Iron 2 Corten

**Kerlite** Laminated porcelain stoneware Thickness 6,5 mm

LITHOS	Naturale - Soft	Class A2-s1, d0 (WALL)	Class A2 <sub>fl</sub> -s1 (FLOOR)	Class A	A Naturale, Soft (Desert, Carbon) B Soft (Moon, Stone)	2
PIETRA D'ISEO	Natural				A	1
VANITY	Glossy - Touch				B	2
WOODLAND	Soft - Wild				A	1

# COTTO D'ESTE GUARANTEE

	RESIDENTIAL	PUBLIC	
	GUARANTEED 20 YEARS	GUARANTEED 10 YEARS	GUARANTEED 20 YEARS

**Kerlite** Laminated porcelain stoneware Thickness 3,5 mm

BLACK-WHITE					
BUXY					
CLUNY	Naturale				
OVER	Naturale				
OVER	Soft	Road	Openspace, Loft, Office		Road
WONDERWALL		Matrix, Ritmi		Matrix, Ritmi	

**Kerlite** Laminated porcelain stoneware Thickness 5,5 mm

BLACK-WHITE	Glossy				
BLACK-WHITE	Silk				
CEMENT PROJECT	Work - Cem				
CLUNY	Layé				
ELEGANCE	Silk				
EXEDRA	Glossy				
EXEDRA	Silk				
FOREST					
LIMESTONE	Natural				
MATERICA					
METAL					

**Kerlite** Laminated porcelain stoneware Thickness 6,5 mm

LITHOS	Naturale - Soft				
PIETRA D'ISEO	Naturale				
VANITY	Glossy - Touch				
WOODLAND	Soft - Wild				



# SIZES

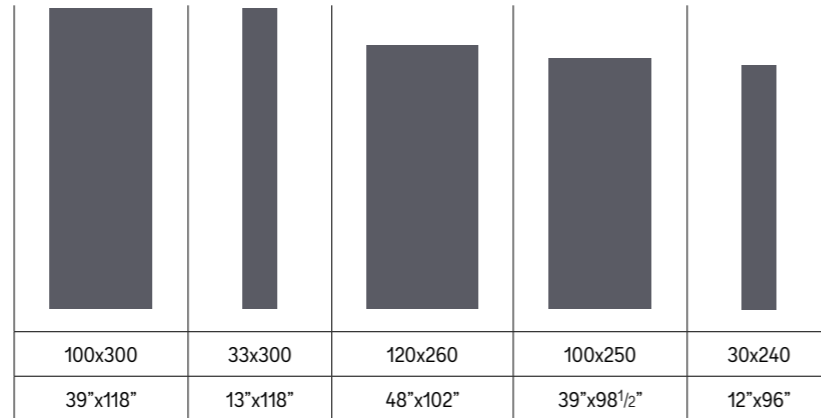

**K-rite** Laminated porcelain stoneware Thickness 3,5 mm

<b>BLACK-WHITE</b>					
<b>BUXY</b>					
<b>CLUNY</b>	Naturale	•			
<b>OVER</b>	Naturale				
	Soft				
<b>WONDERWALL</b>					

**K-rite** Laminated porcelain stoneware Thickness 5,5 mm

<b>BLACK-WHITE</b>	Glossy - Silk				
<b>CEMENT PROJECT</b>	Work				
	Cem				
<b>CLUNY</b>	Layé				
<b>ELEGANCE</b>	Silk	•			
<b>EXEDRA</b>	Glossy - Silk			•	
<b>FOREST</b>			•		
<b>LIMESTONE</b>	Natural				
<b>MATERICA</b>				•	
<b>METAL</b>					

**K-rite** Laminated porcelain stoneware Thickness 6,5 mm

<b>LITHOS</b>	Naturale - Soft				
<b>PIETRA D'ISEO</b>	Naturale		•		
<b>VANITY</b>	Glossy - Touch				
<b>WOODLAND</b>	Soft - Wild				•

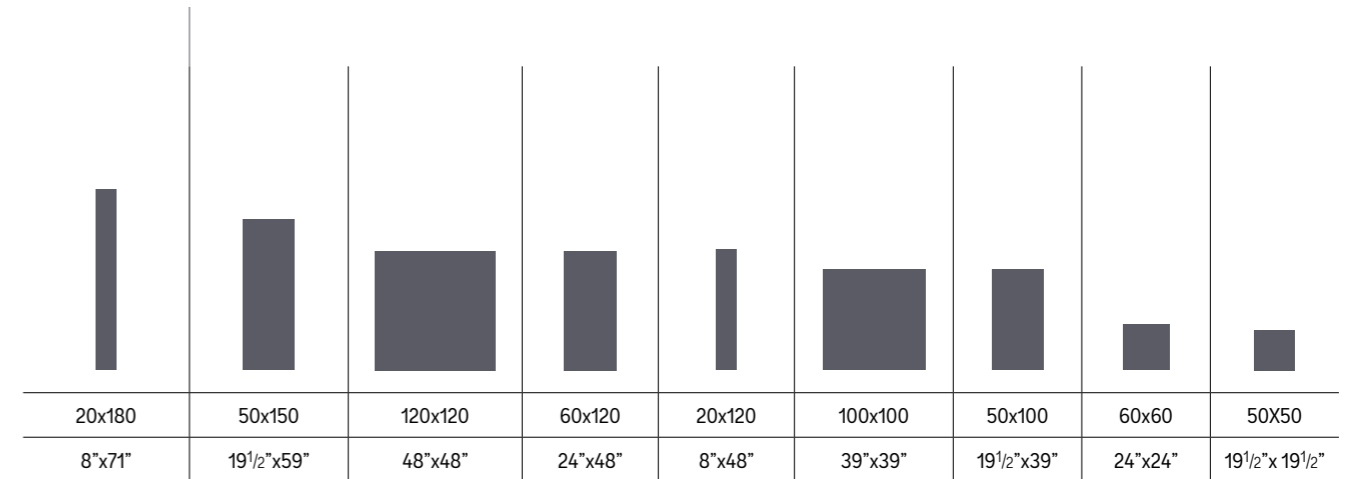

**K-rite** Laminated porcelain stoneware Thickness 3,5 mm

						•		•
					•			•
						•		•
					•			

**K-rite** Laminated porcelain stoneware Thickness 5,5 mm

					•	•		
	•							
					•			•
•				•				
					•	•		

**K-rite** Laminated porcelain stoneware Thickness 6,5 mm

		•	•					•
				•				



# CERTIFICATIONS



## EMAS APPROVED ENVIRONMENTAL MANAGEMENT SYSTEM OF PRODUCTION SITES

The Community Eco-Management and Audit Scheme (EMAS) is the tool through which the European Union promotes continuous improvement of the environmental performance of organizations - ref. Regulations (CE) 1221/2009 and (UE) 2017/1505 of the European Parliament and Council. Cotto d'Este has obtained EMAS Registration for all its production sites: Fiorano Modenese (MO) (registration n.I-000401 on December 2005). This registration is of major importance, since it requires a proper Environmental Management System to be created, based on the continual improvement of environmental performance within organisations. The scheme is based on the creation of an open dialogue with local institutions (Agencies, Authorities, Associations, Trade Union Representatives, Schools, Press) and with the public, and it is expected that all employees will play an active part. The Environmental Statement is the end document that describes the environmental and safety aspects in the workplace, the environmental performance of the site and the environmental targets that the Company sets itself within the framework of continual improvement. The statement is validated by an Accredited Environmental Verifier, following audits carried out in the plant. Cotto d'Este is one of the very few ceramics companies to have EMAS registration which, together with ISO 14001 quality certification, bear witness to the management's utmost commitment and readiness to engage with the ethical, environmental, safety and quality issues.



## LEED V4 CREDITS

Cotto d'Este is a member of the U.S. Green Building Council and of the Green Building Council ITALIA. These organizations promote the construction of buildings and other works which respect the environment as well as the health and well-being of the people who live and work within them. LEED V4 was created by the U.S. Green Building Council to provide designers, architects, and builders with a new tool for the construction of buildings that adhere to more elevated standards of sustainability, health, and liveability. More stringent and thorough requisites are required of building materials, like ceramic tiles, including the Environmental Product Declaration (EPD). **The LEED data sheets for Cotto d'Este are available upon request, according to both the LEED V4 and GBC Italia protocols.**



## EPD - ENVIRONMENTAL PRODUCT DECLARATION

### EPD - Environmental Product Declaration

The Environmental Product Declaration (EPD) is a transparency tool that communicates the environmental performances of Cotto d'Este porcelain tile through a Life Cycle Assessment (LCA). This is a Sector-wide EPD, certified in October 2016 by an independent third party according to official guidelines (PCR), requested by the primary building certification systems such as **LEED** (international), **BREEAM** (England), **HQE** (France), and **DGNB** (Germany), as well as the legislative frameworks in **Italy** (requisites for sustainable public contracts). It is a voluntary certification that gives additional value to Cotto d'Este products because they are manufactured according to the highest standards of sustainability and responsibility.

UNI EN ISO 14001:2015



CERTIFIED ENVIRONMENTAL MANAGEMENT SYSTEM

## UNI EN ISO 14001 ENVIRONMENTAL CERTIFICATION FOR PRODUCTION SITES



## GREENGUARD GOLD

All porcelain stoneware and Kerlite Cotto d'Este collections have obtained GREENGUARD GOLD certification, i.e. the UL standard with the strictest VOC emission limits, and are therefore able to ensure that they are as healthy as possible for the people who use and inhabit these environments. They can therefore be used in environments such as schools and health facilities, attended by sensitive individuals such as children and the elderly. GREENGUARD GOLD is a widely recognised certification required by sustainable building programmes and design and construction regulations around the world, such as LEED (international) and BREEAM (UK).

<b>CE</b>	
DOP001EST DOP004EST DOP005EST	
05	
<b>COTTO D'ESTE</b> Nuove Superfici via Emilia Romagna, 31 - 41049 Sassuolo (MO) - Italy Panariagroup Industrie Ceramiche S.p.A.	<p>Cotto d'Este Porcelain Tiles: Dry-pressed ceramic tiles with low water absorption <math>E \leq 0,5\%</math> for flooring and wall finishes, internal and external applications (DOP001EST).</p> <p style="text-align: center;"><b>EN 14411</b></p> <p>Kerlite 3 Plus: Dry pressed ceramic tiles with low water absorption <math>E \leq 0,5\%</math> for internal flooring and internal and external wall applications (DOP004EST).</p> <p>Kerlite 5 Plus/6 Plus: Dry pressed ceramic tiles with low water absorption <math>E \leq 0,5\%</math> for internal flooring and internal and external wall applications (DOP005EST).</p>

## CE SECURITY MARK

The CE mark is the safety product certification required by EU and it is finalized to preserve the people's health and the goods in buildings. The new Regulation UE N. 305/2011 is valid from the first of July 2013. The most important news is the introduction of the Declaration Of Performance (DOP) with which the supplier communicates the safety requirements concerning own materials. Kerlite porcelain stoneware slabs have the CE mark (cf. DOP004EST-DOP005EST). The application of a fibreglass mesh on the back confer to these products the categories of fire resistance indicated in the Kerlite technical tables. Cotto d'Este DOP are available on the website [www.cottodeste.it](http://www.cottodeste.it) design and construction regulations around the world, such as LEED (international) and BREEAM (UK).



## THE TRADEMARK OF THE ITALIAN CERAMIC INDUSTRY

Ceramics of Italy is the institutional trademark that represents and promotes Italian ceramic industries on a worldwide level. Through Panariagroup SpA, Cotto d'Este can label its products with the Ceramics of Italy trademark, which confirms their high standard of design, the use of the latest technology, concern for the environment and for safety at work and constant research for optimising the resources employed, in compliance with the highest performance standards. Ceramics of Italy embodies the will of the Italian ceramic tile industry to promote the awareness and esteem of Italian ceramic tiles amongst international users: ceramic tiles are not mere building materials but a reference point for style and creativity and for the development of a new way of living. Made in Italy. Ceramics of Italy, promoted by Confindustria Ceramica, is a registered trademark of Edi.Cer. Spa, the organiser of Cersaie - the International ceramics exhibition.



FOLLOW US ON:



Headquarter in Italy

Via Emilia Romagna 31

41049 Sassuolo (MO), Italy

[www.kerlite.it](http://www.kerlite.it)

[www.cottodeste.it](http://www.cottodeste.it)

[info@panariagrouptrade.it](mailto:info@panariagrouptrade.it)

tel +39 0536 915415

fax +39 0536 915400



